



**KCC**

**Xion™ Rooftop Units**  
**Standard Efficiency - 60 Hz**

**COMMERCIAL**  
**PRODUCT SPECIFICATIONS**

Bulletin No. 210990  
 June 2023  
 Supersedes March 2023

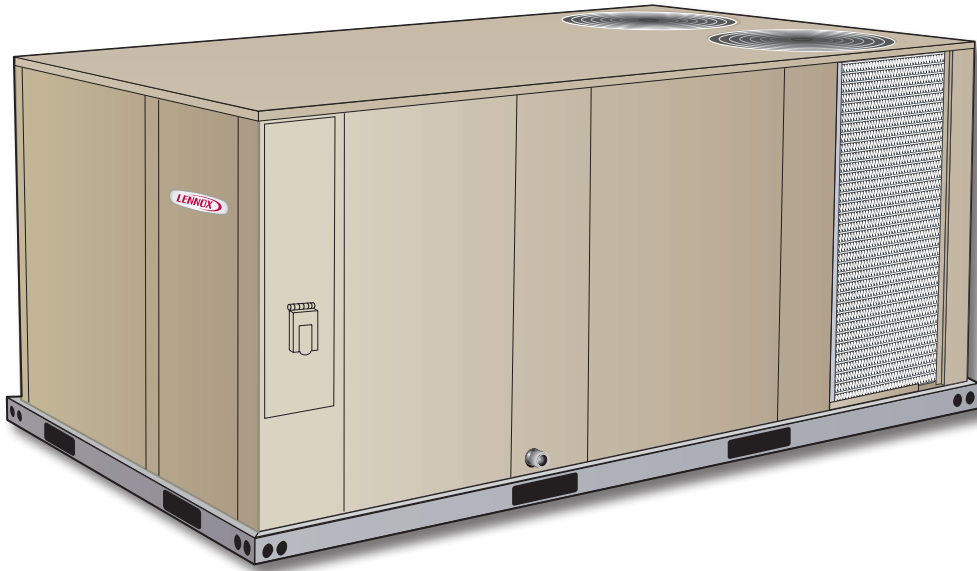

**XION**



**7.5 to 12.5 Tons**  
**Net Cooling Capacity - 86,000 to 138,000 Btuh**  
**Optional Electric Heat - 7.5 to 60 kW**

**MODEL NUMBER IDENTIFICATION**

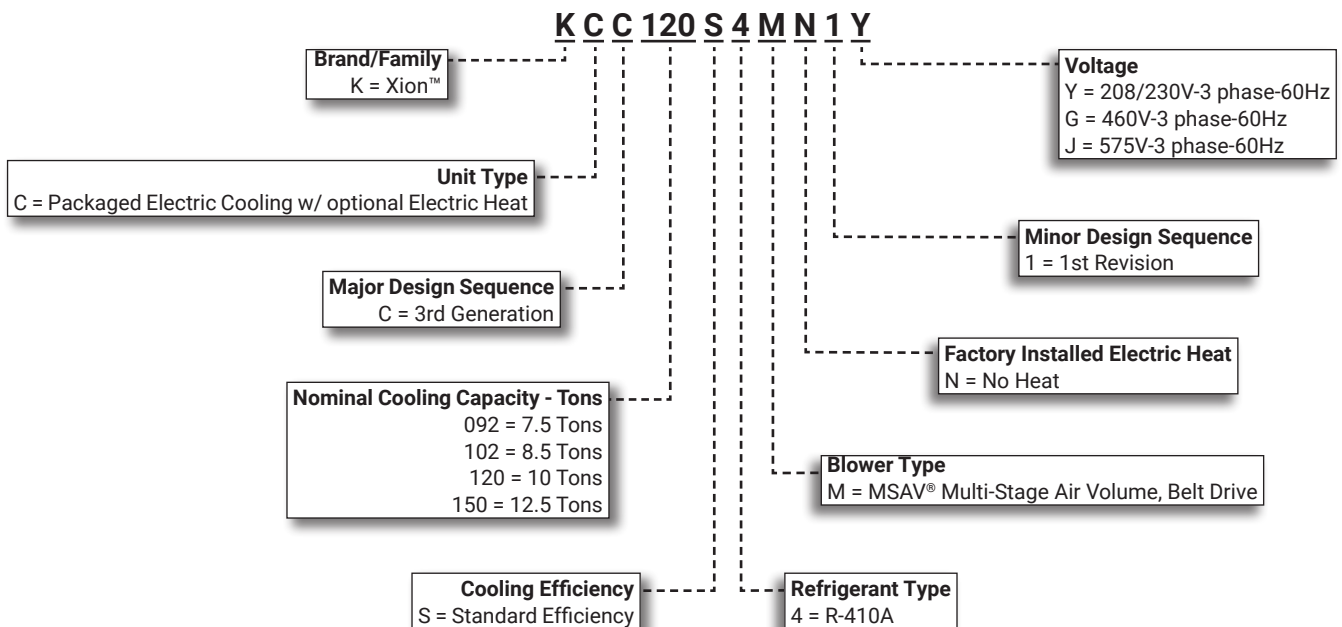

## FEATURE HIGHLIGHTS

Xion™ rooftop units are engineered with the right technologies and options to meet standard efficiency requirements while delivering reliable performance and year-round comfort.

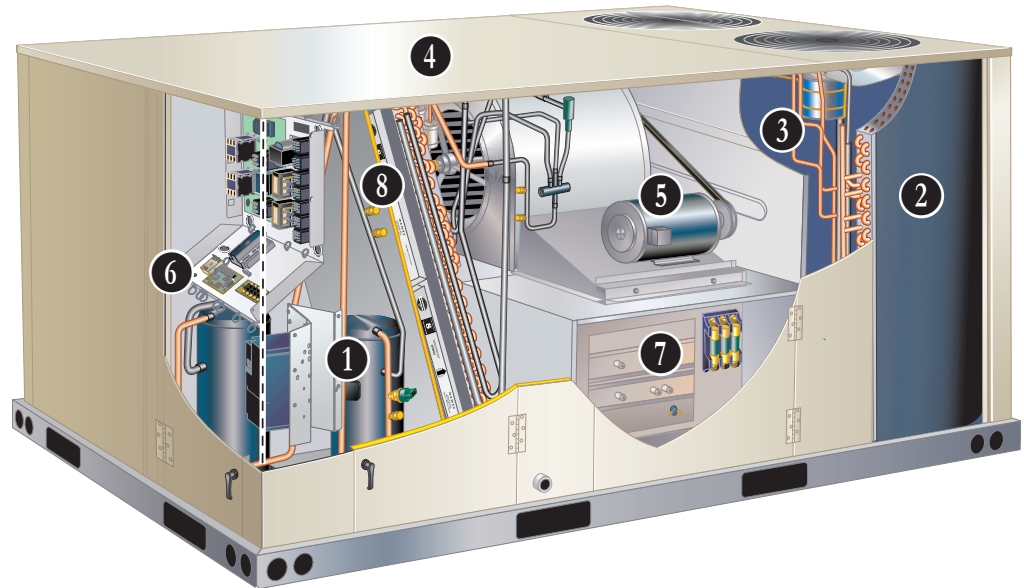

1. Scroll Compressors
2. Environ™ Coil System
3. Outdoor Coil Fan Motors
4. Heavy Gauge Steel Cabinet
5. MSAV Multi-Stage Air Volume Blower
6. Unit Control
7. Electric Heat (option)
8. Air Filter

## CONTENTS

Approvals And Warranty . . . . .	3
Blower Data . . . . .	25
- Belt Drive - 7.5   8.5 Ton . . . . .	25
- Belt Drive - 10   12.5 Ton . . . . .	26
Dimensions . . . . .	36
- Accessories . . . . .	37
- Unit . . . . .	36
Electrical/Electric Heat Data . . . . .	29
- 7.5 Ton . . . . .	29
- 8.5 Ton . . . . .	30
- 10 Ton . . . . .	31
- 12.5 Ton . . . . .	32
Electric Heat Capacities . . . . .	33
Features And Benefits . . . . .	3
Humiditrol® Dehumidification System Option . . . . .	11
Humiditrol® Dehumidification System Ratings . . . . .	23
Model Number Identification . . . . .	1
Optional Conventional Temperature Control Systems . . . . .	12
Options / Accessories . . . . .	15
Outdoor Sound Data . . . . .	34
Ratings . . . . .	19
Sequence Of Operation . . . . .	13
Specifications . . . . .	18
Unit Clearances . . . . .	34
Weight Data . . . . .	35

## APPROVALS AND WARRANTY

### **APPROVALS**

- AHRI Standard 340/360 certified
- ETL and CSA listed
- CSA certified energy ratings
- Unit and components are ETL, NEC, and CEC bonded for grounding to meet safety standards for servicing
- All models are ASHRAE 90.1 energy efficiency compliant and meet or exceed requirements of Section 6.8
- All models meet DOE 2023 energy efficiency standards
- A models meet California Code of Regulations, Title 24 and ASHRAE 90.1-2010 Section 6.4.3.10 requirements for staged airflow
- ISO 9001 Registered Manufacturing Quality System

### **WARRANTY**

- Compressors - Limited five years
- Environ™ Coil System - Limited three years
- Variable-Frequency Drive (VFD) - Limited five years
- High Performance Economizers (optional) - Limited five years
- All other covered components - Limited one year

## FEATURES AND BENEFITS

### **COOLING SYSTEM**

- Designed to maximize sensible and latent cooling performance at design conditions
- System can operate from 45°F to 125°F without any additional controls

#### **R-410A Refrigerant**

- Non-chlorine based
- Ozone friendly

#### **1 Compressor System**

- System consists of one two-stage scroll compressor and one single-stage scroll compressor
- Resiliently mounted on rubber grommets for quiet operation

#### **Compressor Crankcase Heaters**

- Protects against refrigerant migration that can occur during low ambient operation or during extended off cycles

#### **Thermal Expansion Valves**

- Ensures optimal performance throughout the application range
- Removeable power element

#### **Filter/Driers**

- High capacity filter/drier protects the system from dirt and moisture

#### **High Pressure Switches**

- Protects the compressor from overload conditions such as dirty condenser coils, blocked refrigerant flow or loss of outdoor fan operation
- Automatic reset

#### **Indoor Coil Freeze Protection**

- Protects the evaporator coil from damaging ice build-up due to conditions such as low/no airflow or low refrigerant charge

#### **2 Condenser Coil - Environ™ Coil System**

- Lightweight, all aluminum brazed fin construction
- Constructed of three components
  - A flat extrusion tube
  - Fins in-between the flat extrusion tube
  - Two refrigerant manifolds

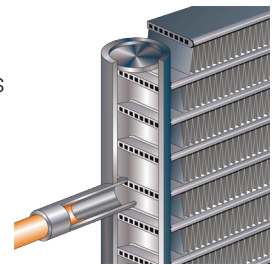

#### **Environ™ Coil System Features:**

- Improved heat transfer performance due to high primary surface area (flat tubes) versus secondary surface (fins)
- Smaller internal volume (reduced refrigerant charge)
- High durability
- All aluminum construction
- Fewer brazed joints
- Compact design
- Reduced unit weight
- Easy maintenance/cleaning
- Mounting brackets with rubber inserts secure coil to unit providing vibration dampening and corrosion protection

#### **Evaporator Coil**

- Copper tube construction
- Enhanced rippled-edge aluminum fins
- Flared shoulder tubing connections
- Silver soldered construction
- Factory leak tested
- Cross-row circuiting with rifled tubing

## FEATURES AND BENEFITS

### COOLING SYSTEM (continued)

#### Antimicrobial Condensate Drain Pan

- Composite pan, sloped to meet drainage requirements of ASHRAE 62.1
- Antimicrobial additive resists growth of mold and mildew on drain pan, which improves indoor air quality and reduces drain line blockage
- Side or bottom drain connections
- Reversible to allow connection at back of unit

### **3** Outdoor Coil Fan Motors

- Thermal overload protected
- Totally enclosed
- Permanently lubricated ball bearings
- Shaft up
- Wire basket mount

#### Outdoor Coil Fans

- PVC coated fan guard furnished

### Required Selections

#### Cooling Capacity

- Specify nominal cooling capacity

### Options/Accessories

#### Factory Installed

##### Conventional Fin/Tube Condenser Coil (replaces Environ™ Coil System)

**NOTE** - Required if Humiditrol® Dehumidification System is ordered.

- Copper tube construction
- Enhanced rippled-edge aluminum fins
- Flared shoulder tubing connections
- Silver soldered construction

#### Field Installed

##### Condensate Drain Trap

- Available in copper or PVC

##### Drain Pan Overflow Switch

- Monitors condensate level in drain pan
- Shuts down unit if drain becomes clogged

##### Low Ambient Control Kit (0°F)

- Units operate satisfactorily down to 45°F outdoor air temperature without any additional controls
- Allows unit operation down to 0°F without evaporator coil icing
- Head pressure speed control reduces outdoor fan operation during low ambient conditions until head pressure rises to the setpoint
- Pressure transducers are mounted on the liquid lines
- High pressure switches are furnished to replace existing
- Wiring harnesses are furnished for simple plug-in wiring to fans and controller

### CABINET

### **4** Construction

- Heavy-gauge steel panels
- Full perimeter heavy-gauge galvanized steel base rail
- Base rails have rigging holes
- Three sides of the base rail have forklift slots
- Raised edges around duct and power entry openings in the bottom of the unit for water protection

#### Airflow Choice

- Units are shipped in downflow (vertical) return air flow configuration

**NOTE** - Units can be field converted to horizontal airflow with optional Horizontal Discharge Kit.

#### Duct Flanges

- Provided for horizontal duct attachment

#### Power Entry

- Electrical lines can be routed through the unit base or through horizontal access knock-outs

#### Exterior Panels

- Constructed of heavy-gauge, galvanized steel
- Textured pre-paint with polyurethane finish
- Cyclic salt fog and UV exposure up to 1,680 hours per ASTM D5894

#### Insulation

- Fully insulated with non-hygroscopic fiberglass insulation (conditioned areas)
- Unit base is fully insulated
- Base insulation serves as an air seal to the roof curb, eliminating the need to add a seal during installation

#### Access Panels

- Filter section
- Blower/heating section
- Compressor/controls section

## FEATURES AND BENEFITS

### **CABINET (continued)**

#### Options/Accessories

#### **Factory Installed**

##### Hinged Access Panels

- Tool-less access
- Filter section
- Blower/heating section
- Compressor/controls section
- Panel seals and quarter-turn latching handles provide a tight air and water seal

#### **Factory or Field Installed**

##### Combination Coil/Hail Guards

- Heavy gauge steel frame
- Painted to match cabinet
- Expanded metal mesh protects outdoor coil

#### **Field Installed**

##### Horizontal Discharge Kit

- Consists of duct covers to block off downflow supply and return air openings for horizontal applications
- Also includes return air duct flanges for end return air when economizer is used in horizontal applications

**NOTE** - When configuring unit for horizontal application with economizer, a separate Horizontal Barometric Relief Damper with Hood must be ordered separately for installation in the return air duct.

##### Return Air Adaptor Plate

- For same size L Series® and T-Class™ unit replacement
- Installs on return air opening in unit to match return air opening on existing roof curbs
- Also see Accessory Air Resistance table

### **BLOWER**

A wide selection of supply air blower options are available to meet a variety of airflow requirements

#### **5** Blower Motor

- Overload protected
- Ball bearings
- Available in several different sizes to maximize air performance

#### Supply Air Blower

- Forward curved blades
- Double inlet
- Blower wheel statically and dynamically balanced
- Ball bearings
- Adjustable pulley (allows speed change).
- Blower assembly slides out of unit for servicing

#### MSAV Multi-Stage Air Volume Operation

- MSAV Multi-Stage Air Volume stages the amount of airflow according to compressor stages, heating demand, and ventilation demand
- Units utilize a Variable Frequency Drive (VFD) to stage the supply air blower airflow
- VFD alters the frequency and voltage of the power supply to the blower to control blower speed
- The supply air blower has three speeds:
  1. **Low Speed** - 1st Stage Cooling
  2. **Medium Speed** - 2nd Stage Cooling
  3. **High Speed** - Full load cooling and all heat modes
- Full speed blower operation is set by adjusting the motor pulley to deliver the desired air volume
- Ventilation speed is selectable between high and low speed

**NOTE** - Part load airflow in cooling mode should not be set below 220 cfm/nominal full load ton to reduce the risk of evaporator coil freeze-up.

- VFD has an operational range of -40 to 125° F outdoor air ambient temperature

**NOTE** - Lower operating costs are obtained when the blower is operated on lower speeds.

## FEATURES AND BENEFITS

### **BLOWER (Continued)**

**NOTE** - Variable Frequency Drive (VFD) is designed to operate on balanced, three-phase power. Operating units on unbalanced three-phase power will reduce the reliability of all electrical components in the unit. Unbalanced power is a result of the power delivery system supplied by the local utility company. Factory-installed inverters are sized to drive blower motors with an equivalent current rating using balanced three-phase power. If unbalanced three-phase power is supplied the installer must replace the existing factory-installed inverter with an inverter that has a higher current rating to allow for the imbalance. Refer to the installation instructions for additional information and replacement information.

### **Required Selections**

- Order blower motor horsepower and drive kit number required when base unit is ordered
- See Drive Kit Specifications Table

### **Options/Accessories**

#### **Field Installed**

##### **VFD Manual Bypass Kit**

- Bypass Kit can be used to operate the unit in single speed (CAV) blower mode if the inverter needs to be serviced or replaced
- VFD Manual Bypass Control is a manual bypass and is set by re-configuring the wiring on the unit

### **CONTROLS**

#### **6 Unit Control**

- All control voltage is provided via a 24V (secondary) transformer with built-in circuit breaker protection
- **Heat/Cool Staging** - Capable of up to 2 heat / 3 cool staging with a third party DDC control system or thermostat
- **Low Voltage Terminal Block** - Provides screw terminal connections for thermostat or controller wiring

### **Options/Accessories**

#### **Field Installed**

##### **Smoke Detector**

- Photoelectric type
- Installed in supply air section, return air section or both sections
- Available with power board and single sensor (supply or return) or power board and two sensors (supply and return)

#### **Commercial Control Systems**

##### **Thermostats**

- Control system and thermostat options, see page 12

#### **ELECTRICAL**

##### **Marked & Color-Coded Wiring**

- All electrical wiring is color-coded and marked to identify which components it is connecting

##### **Electrical Plugs**

- Positive connection electrical plugs are used to connect common accessories or maintenance parts for easy removal or installation

##### **Phase Monitor**

- Phase monitor located in the control compartment detects the phasing of incoming power
- If the incoming power is out of phase or if any of the three phases are lost, an indicator LED on the phase monitor will turn red and the unit will not start
- In normal operation with correct incoming power phasing, the LED will be green

### **Required Selections**

#### **Voltage Choice**

- Specify when ordering base unit

## FEATURES AND BENEFITS

### ELECTRICAL (Continued)

#### Options/Accessories

#### **Factory or Field Installed**

##### Disconnect Switch

- Accessible from outside of unit
- Spring loaded weatherproof cover
- See Electrical/Electric Heat tables for ordering information, page 29

##### GFI Service Outlets (2)

- 115V ground fault circuit interrupter (GFCI) type options:
  - Factory installed, non-powered, field wired
  - Field installed, non-powered, field wired

#### **Field Installed**

#### 7 Electric Heat

- Helix wound nichrome elements
- Individual element limit controls
- Wiring harness
- Unit fuse block
- See Options / Accessories tables for ordering information

##### GFI Weatherproof Cover

- Single-gang cover
- Heavy-duty UV-resistant polycarbonate case construction
- Hinged base cover with gasket

### INDOOR AIR QUALITY

#### 8 Air Filters

- Disposable 2 inch MERV 4 filters furnished as standard

#### Options/Accessories

#### **Field Installed**

##### Healthy Climate® High Efficiency Air Filters

- Disposable MERV 8, MERV 13, or MERV 16 (Minimum Efficiency Reporting Value based on ASHRAE 52.2) efficiency
- 2 inch pleated filters

##### Replacement Filter Media Kit With Frame

- Replaces existing pleated filter media
- Includes washable metal mesh screen and metal frame with clip for holding replaceable non-pleated filter

##### Indoor Air Quality (CO<sub>2</sub>) Sensors

- Monitors CO<sub>2</sub> levels and reports to the Unit Controller which adjusts economizer dampers as needed

### Healthy Climate® UVC Germicidal Lamps

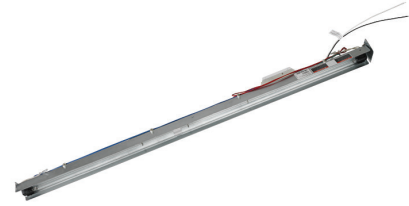

- Germicidal lamps emit ultra-violet (UV-C) energy, which has been proven to be effective in reducing microbes such as viruses, bacteria, yeasts, and molds
- UV-C energy greatly reduces the growth and proliferation of mold and other bioaerosols (bacteria and viruses) on illuminated surfaces (particularly coil and drain pan)
- Destroys the organism or controls its ability to reproduce
- Field installed in the blower/evaporator coil section
- Magnetic safety interlock terminates power when access panels are removed
- All necessary hardware for installation is included
- Lamps operate on 110/230V-1ph power supply
- **NOTE** - Step-down transformer may be ordered separately for 460V and 575V units.
- Approved by ETL
- 

#### Needlepoint Bipolar Ionization (NPBI) Kit

- NPBI technology has been shown to effectively reduce harmful pathogens, pollutants, and odors
- **NOTE** - Please visit [www.sciencedirect.com](http://www.sciencedirect.com) for additional information.
- Brush-type ionizer introduces a high concentration of both positive and negative ions into the air stream
- These bipolar ions are then dispersed into the occupied space through the duct system proactively reducing the airborne contaminants
- Ions travel within the building air stream and attach to particles, pathogens, and gas molecules, making them larger and easier to capture in the filtration system
- UL 2998 certified for zero ozone emission



## OPTIONS / ACCESSORIES

### ECONOMIZER (continued)

#### High Performance Economizer Control Module

- Provides inputs and outputs to control economizer based on parameter settings
- Free cooling based on single dry bulb temperature, or combination temperature + humidity sensors
- Automatic switchover for different control modes
- Parameter settings based on climate zone, using GPS functionality in the Climatix Mobile application
- LED indication for free cooling operation, sensor operation and damper operation
- Quick installation and easy commissioning with the Climatix Mobile App on a mobile device

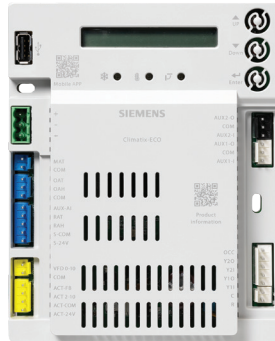

**NOTE** - WLAN Stick is required for App connection to module(s).

- Module displays any alarm messages (fault detection and diagnostics) as an aid in troubleshooting
- RS485 port for BACnet MS/TP or Modbus RTU communication
- USB port for firmware updates and WLAN connection for setup and commissioning
- QR codes on module for quick access to download Climatix Mobile App and user documentation
- User Interface for normal operation, parameter setup, and alarm notifications with an LCD display and three operation buttons:
  1. **Up Button** - Move to the previous value, step or category
  2. **Down Button** - Move to the next value, step or category
  3. **Enter Button** -
    - Press to edit the current value or option
    - Press to confirm a newly selected value or option
    - Press Enter + Up to jump up one category
    - Press Enter + Down to jump down one category

**NOTE** - The Free Cooling setpoint for Title 24 applications must be set based on the Climate Zone where the system is installed. See Section 140.4 "Prescriptive Requirements for Space Conditioning Systems" of the California Energy Commission's 2013 Building Energy Efficiency Standards.

**NOTE** - Refer to Installation Instructions for complete setup information and menu parameters available.

### Field Installed

#### Single Enthalpy Temperature Control

- Outdoor air enthalpy sensor enables Economizer if the outdoor enthalpy is less than the setpoint of the control

**NOTE** - The factory installed economizer option comes preset for Single Enthalpy control but can be field converted to Single Sensible temperature control by changing a parameter on the economizer control module.

#### Differential Enthalpy Control (Not for Title 24)

- Order one for factory installed economizer
- Order two for field installed economizer
  - One is field installed in the return air section
  - One in the outdoor air section
- Allows the economizer control board to select between outdoor air or return air, whichever has lower enthalpy

#### WLAN Stick

- Required for Climatix Mobile App usage
- Plugs into USB port on Module to provide a temporary WLAN connection for setup, commissioning, and servicing

**NOTE** - Only one WLAN Stick is required and can be used on multiple modules.

### EXHAUST

#### Field Installed

#### Horizontal Low Profile Barometric Relief Dampers

- Replaces barometric relief dampers furnished with Economizer
- For use when unit is configured for horizontal applications in a reduced space requiring an economizer
- Allows relief of excess air
- Aluminum blade dampers prevent blow back and outdoor air infiltration during off cycle
- Field installed in return air duct
- Exhaust hood with bird screen furnished

**NOTE** - Requires Horizontal Discharge Kit

#### Power Exhaust Fan

- Installs internal to unit for downflow applications only with economizer option
- Provides exhaust air pressure relief
- Interlocked to run when supply air blower is operating,
- Fan runs when outdoor air dampers are 50% open (adjustable)
- Motor is overload protected
- Fan is 20 in. diameter
- Five blades
- One 1/3 hp motor

**NOTE** - Requires Economizer and Downflow Barometric Relief Dampers.

## OPTIONS / ACCESSORIES

### **OUTDOOR AIR**

#### **Field Installed**

##### **Outdoor Air Damper**

- Downflow or Horizontal
- Linked mechanical dampers
- 0 to 25% (fixed) outdoor air adjustable
- Installs in unit
- Includes outdoor air hood
- Motorized model features fully modulating spring return damper motor with plug-in connection
- Manual model features parallel blade, gear-driven dampers with adjustable fixed position

**NOTE** - Maximum mixed air temperature in cooling mode is 100°F.

### **ROOF CURBS**

#### **Field Installed**

- Nailer strip furnished (downflow only)
- Mates to unit
- US National Roofing Contractors Approved
- Shipped knocked down

##### **Hybrid Roof Curbs, Downflow**

- Interlocking tabs fasten corners together
- No tools required for assembly
- Can also be fastened together with furnished hardware
- Available in 8, 14, 18, and 24 inch heights

##### **Adjustable Pitch Curb**

- Fully adjustable pitch curbs (3/4 in. per foot in any direction) provide a level platform for rooftop units allowing flexible installations on roofs with uneven or sloped angles
- Interlocking tabs fasten corners together
- No tools required for assembly
- Hardware is furnished to connect upper curb with lower curb
- Available in 14 inch height

##### **Adaptor Curbs (not shown)**

- Curbs are regionally sourced
- Dimensions vary based upon the source

**NOTE** - Contact your local sales representative for a detailed cut sheet with applicable dimensions.

### **CEILING DIFFUSERS**

#### **Field Installed**

##### **Ceiling Diffusers (Flush or Step-Down)**

- White powder coat finish on diffuser face and grilles
- Insulated UL listed duct liner
- Diffuser box has collars for duct connection
- Step-down diffusers have double deflection blades
- Flush diffusers have fixed blades
- Provisions for suspending
- Internally sealed to prevent recirculation
- Removable return air grille
- Adapts to T-bar ceiling grids or plaster ceilings

##### **Transitions (Supply and Return)**

- Used with diffusers
- Installs in roof curb
- Galvanized steel construction
- Flanges furnished for duct connection to diffusers
- Fully insulated

# HUMIDITROL® DEHUMIDIFICATION SYSTEM OPTION

## OVERVIEW

**NOTE** - Not available with Environ™ Coil System.  
Conventional Fin/Tube condenser coil must be ordered as a factory option.

- Factory installed option designed to control humidity
- Provides dehumidification on demand using ASHRAE 90.1 recommended method for comfort conditioning humidity control
- Unit comes equipped with one row reheat coil, solenoid valve and humidity controller
- A thermostat with a dehumidification output, a dehumidistat, or a DDC controller with an isolated output is required to control humidity and must be located in the occupied space

**NOTE** - Controls are not furnished and must be ordered separately.

## BENEFITS

- Improves indoor air quality
- Helps prevent damage due to high humidity levels
- Improves comfort levels by reducing space humidity levels

## OPERATION

### No Dehumidification Demand

- Unit will operate conventionally whenever there is a demand for cooling or heating and no dehumidification demand
- Free cooling is only permitted when there is no demand for dehumidification

### Dehumidification Demand Only

- Dehumidification is initiated by an output from a dehumidistat (furnished), an optional thermostat with a dehumidification output or an optional DDC controller with an isolated output to control humidity
- Reheat operation will initiate on a dehumidification demand and does not require a cooling demand
- Unit will operate in the dehumidification mode until the relative humidity of the conditioned space is below the setpoint
- This operation reduces sensible cooling capacity and extends compressor run time to control humidity when the cooling load is low
- A solenoid valve diverts hot gas from the compressor to the reheat coil
- Cooled and dehumidified air from the evaporator is reheated as it passes through the reheat coil
- De-superheated and partially condensed refrigerant continues to the outdoor condenser coil where condensing is completed
- Unit will continue to operate in this mode until the dehumidification demand is satisfied

### Field Installed

#### CS7500 Thermostat

- Dehumidification control
- Adjustable from 45-60% relative humidity
- Remotely installed in the conditioned space

**NOTE** - A dehumidistat with a dehumidification output or a DDC controller with an isolated output can be used instead (field furnished).

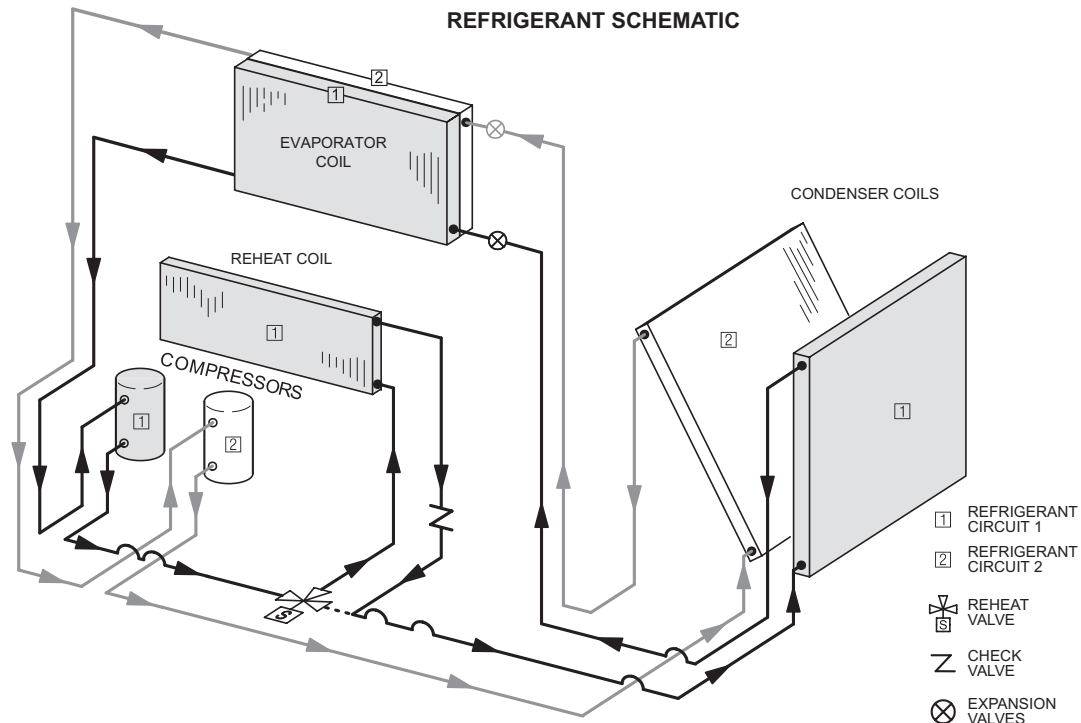

## OPTIONAL CONVENTIONAL TEMPERATURE CONTROL SYSTEMS

### CS7500 Commercial 7-Day Programmable Thermostat



- Premium Universal Thermostat
- Full Color Touchscreen Interface
- Up To 4 Heat / 3 Cool
- Built-In Sensors For Temperature and Humidity
- Remote Sensors Options For Temperature, Discharge Air, Outdoor Air
- 5-2 or 7-Day Scheduling
- Smooth Setback Recovery
- Heat/Cool Auto-Changeover
- FDD, ASHRAE, IECC Compliant

### CS3000 Commercial 5-2 Day Programmable Thermostat



- Conventional Multi-Stage Thermostat
- Intuitive Display
- Push-Button Operation
- Up To 2 Heat / 2 Cool
- Built-In Temperature Sensor
- Remote Temperature Sensing
- Up to 5-2 Day Scheduling
- Smooth Setback Recovery
- Heat/Cool Auto-changeover

### BACnet Compatible Thermostat With Reheat



Description	Catalog No.
<b>CS7500 Commercial 7-Day Programmable Thermostat</b>	
CS7500 7-Day Thermostat	<b>24K41</b>
Sensors/	<sup>1</sup> Remote non-adjustable wall-mount 20k <b>47W36</b>
Accessories	<sup>1</sup> Remote non-adjustable wall-mount 10k <b>47W37</b>
	Remote non-adjustable discharge air (duct mount) <b>19L22</b>
	Outdoor temperature sensor <b>X2658</b>
<b>CS3000 5-2 Day Programmable Thermostat</b>	
CS3000 5-2 Day Thermostat	<b>11Y05</b>
Sensor/	Remote non-adjustable wall mount 10k averaging <b>47W37</b>
Accessories	Thermostat wall mounting plate <b>X2659</b>
<b>BACnet 7-Day Programmable Thermostat</b>	
BACnet	<sup>2</sup> 7-Day BACnet Thermostat <b>24C57</b>
Controls	<sup>3</sup> BACnet Module (factory or field) <b>16X71</b>
<sup>4</sup> BACnet	With Display <b>97W23</b>
Room Sensors	Without Display <b>97W24</b>
<b>Universal Thermostat Guard with Lock (clear)</b>	
Inside Dimensions (H x W x D)	5-7/8 x 8-3/8 x 3 in. <b>39P21</b>

- 7-Day Programmable
- For units with or without Humiditrol®
- BTL listed MS/TP ensures compatibility with any BACnet system
- Built-in control programs for conventional and heat pump applications
- Conventional systems up to 3-stage heat and 3-stage cool
- Heat pumps with 1 or 2 compressors and up to 2-stage auxiliary heat
- On-board temperature and humidity sensor
- Multiple configurable inputs and outputs enable advanced control strategies
- Set-up Wizard enables rapid system configuration
- No special tools required for installation or commissioning
- Seven-day (2, 4 or 6 event) occupancy scheduling per day
- Backlit 5-inch LCD touchscreen

<sup>1</sup> Remote wall-mount sensors can be applied in any of the following combinations:  
One Sensor - (1) 47W36, Two Sensors - (2) 47W37, Three Sensors - (2) 47W36 and (1) 47W37

Four Sensors - (4) 47W36, Five Sensors - (3) 47W36 and (2) 47W37

<sup>2</sup> BACnet Thermostat (24C57) will control units with and without the Humiditrol® option. If there is a mix of units equipped with and without Humiditrol on the same site, this thermostat can be used for all units if suitable.

<sup>3</sup> Not compatible with units equipped with Humiditrol® option.

<sup>4</sup> Only compatible with BACnet Module (16X71).

### **UNIT OPERATION WITH 3-STAGE THERMOSTAT (3 COOL AND 2 HEAT STAGES, Y1, Y2, Y3 AND W1, W2)**

#### **SUPPLY AIR BLOWER SPEED**

Unit has three distinct supply air blower speeds:

- Ventilation Speed (High or Low - adjustable)
- Cooling Speed - Low
- Cooling Speed - Medium
- Cooling Speed - High
- Heating speed - High
- Smoke speed (Used only in smoke removal option - not discussed)

#### **<sup>1</sup> Unit Features An Economizer And Outdoor Air Is Suitable**

Cooling - Thermostat Mode (Y1, Y2, Y3)

##### **Y1 Demand:**

All compressors are off, supply air blower is on high cooling speed, economizer modulates (minimum to maximum open position) to maintain 55°F supply air temperature.

##### **Y2 Demand:**

Compressor 1 operates in part load, supply air blower is on low cooling speed, and economizer modulates to maintain 55°F supply air temperature.

##### **Y3 Demand:**

Compressor 1 operates in full load, supply air blower operates at high cooling speed, and economizers modulate to maintain 55°F supply air temperature.

<sup>1</sup> Outdoor air suitability is determined by the energy state of outdoor ambient (enthalpy or sensible) and its ability to achieve the desired free cooling effects.

#### **Unit Does Not Feature An Economizer or Outdoor Air Is Not Suitable**

##### **Y1 Demand:**

Compressor 1 operates at full load and supply air blower operates at low cooling speed.

##### **Y2 Demand:**

Compressor 1 operates at part load with compressor 2 ON, and supply air blower operates at medium cooling speed.

##### **Y3 Demand:**

Compressor 1 operates at full load with compressor 2 ON, supply air blower operates at high cooling speed.

#### **Dehumidification Mode**

If a unit with Humiditrol® Dehumidification Option receives a call for dehumidification, economizer free cooling is locked out.

##### **Call For Dehumidification, No Y1, Y2 Demand:**

1st stage compressor operates at full load, supply air blower operates at low cooling speed, and the reheat valve is energized.

##### **Y1 Demand With A Call For Dehumidification:**

Compressor 1 operates at full load with compressor 2 ON, supply air blower operates at medium cooling speed and the reheat valve is energized.

##### **Y2 Demand With A Call For Dehumidification:**

Compressor 1 operates at part load with compressor 2 ON, supply air blower operates at medium cooling speed, and the reheat valve is de-energized.

##### **Y3 Demand With A Call For Dehumidification:**

Compressor 1 operates at full load with compressor 2 ON, supply air blower operates at high cooling speed, and the reheat valve is de-energized.

**HEATING MODE (GAS HEAT)**

NOTE - HEATING MODE IS THE SAME FOR ALL CONTROL OPTIONS

**W1 Demand:**

1st stage electric heat is energized and the supply air blower operates at heating speed.

**W2 Demand:**

2nd stage electric heat is energized and the supply air blower operates at heating speed (22.5 to 60 kW electric heat option only).

**POWER EXHAUST**

Power exhaust blower operates when economizer outdoor air dampers are 50% open (adjustable).

## OPTIONS / ACCESSORIES

Item Description	Catalog Number	Unit Model No				
		092	102	120	150	
<b>COOLING SYSTEM</b>						
Condensate Drain Trap	PVC	<b>22H54</b>	X	X	X	X
	Copper	<b>76W27</b>	X	X	X	X
Conventional Fin/Tube Condenser Coil (Replaces Environ™ Coil System) (Required for Humiditrol® Dehumidification option)	Factory		O	O	O	O
Drain Pan Overflow Switch		<b>74W42</b>	X	X	X	X
Low Ambient Kits (0°F)		<b>18B87</b>	X	X	X	X
<b>BLOWER - SUPPLY AIR</b>						
Blower Motors	Belt Drive - 2 hp	Factory	O	O	O	O
	Belt Drive - 3 hp	Factory	O	O	O	O
	Belt Drive - 5 hp	Factory	O	O	O	O
VFD Manual Bypass Kit		<b>90W53</b>	X	X	X	X
Drive Kits	Kit #1 590-890 rpm	Factory	O	O	O	O
See Blower Data Tables for selection	Kit #2 800-1105 rpm	Factory	O	O	O	O
	Kit #3 795-1195 rpm	Factory	O	O	O	O
	Kit #4 730-970 rpm	Factory	O	O	O	O
	Kit #5 940-1200 rpm	Factory	O	O	O	O
	Kit #6 1015-1300 rpm	Factory	O	O	O	O
	Kit #10 900-1135 rpm	Factory	O	O	O	O
	Kit #11 1040-1315 rpm	Factory	O	O	O	O
	Kit #12 1125-1425 rpm	Factory	O	O	O	O
	<b>CABINET</b>					
Combination Coil/Hail Guards		<b>24M51</b>	OX	OX		
		<b>24C85</b>			OX	OX
Hinged Access Panels		Factory	O	O	O	O
Horizontal Discharge Kit		<b>51W25</b>	X	X	X	X
Return Air Adaptor Plate (for same size L Series® and T-Class™ replacement)		<b>54W96</b>	X	X	X	X
<b>CONTROLS</b>						
<b>NOTE - Also see Conventional Thermostat Control Systems page 12 for Additional Options.</b>						
Smoke Detector - Supply or Return (Power board and one sensor)		<b>11K76</b>	X	X	X	X
Smoke Detector - Supply and Return (Power board and two sensors)		<b>11K80</b>	X	X	X	X

NOTE - Catalog numbers shown are for ordering field installed accessories.

OX - Configure To Order (Factory Installed) or Field Installed

O = Configure To Order (Factory Installed)

X = Field Installed

## OPTIONS / ACCESSORIES

Item Description	Catalog Number	Unit Model No				
		092	102	120	150	
<b>INDOOR AIR QUALITY</b>						
<b>Air Filters</b>						
Healthy Climate® High Efficiency Air Filters 20 x 25 x 2 (Order 4 per unit)	MERV 8	<b>50W61</b>	X	X	X	X
	MERV 13	<b>52W41</b>	X	X	X	X
	MERV 16	<b>21U41</b>	X	X	X	X
Replaceable Media Filter With Metal Mesh Frame (includes non-pleated filter media) (Order 4 per unit)	20 x 25 x 2	<b>Y3063</b>	X	X	X	X
<b>Indoor Air Quality (CO<sub>2</sub>) Sensors</b>						
Sensor - Wall-mount, off-white plastic cover with LCD display		<b>77N39</b>	X	X	X	X
Sensor - Wall-mount, off-white plastic cover, no display		<b>23V86</b>	X	X	X	X
Sensor - Black plastic case with LCD display, rated for plenum mounting		<b>87N52</b>	X	X	X	X
Sensor - Wall-mount, black plastic case, no display, rated for plenum mounting		<b>87N54</b>	X	X	X	X
CO <sub>2</sub> Sensor Duct Mounting Kit - for downflow applications		<b>85L43</b>	X	X	X	X
Aspiration Box - for duct mounting non-plenum rated CO <sub>2</sub> sensors ( <b>77N39</b> )		<b>90N43</b>	X	X	X	X
<b>Needlepoint Bipolar Ionization (NPBI)</b>						
Needlepoint Bipolar Ionization (NPBI) Kit		<b>22U15</b>	X	X	X	X
<b>UVC Germicidal Lamps</b>						
<sup>1</sup> Healthy Climate® UVC Light Kit (110/230V-1ph)		<b>21A93</b>	X	X	X	X
Step-Down Transformers	460V primary, 230V secondary	<b>10H20</b>	X	X	X	X
	575V primary, 230V secondary	<b>10H21</b>	X	X	X	X
<b>HUMIDITROL® DEHUMIDIFICATION REHEAT OPTION</b>						
Humiditrol® Dehumidification Option		Factory	O	O	O	O
<b>ELECTRICAL</b>						
Voltage 60 Hz	208/230V - 3 phase	Factory	O	O	O	O
	460V - 3 phase	Factory	O	O	O	O
	575V - 3 phase	Factory	O	O	O	O
Disconnect Switch - See Electrical/Electric Heat tables for selection	80 amp	<b>54W56</b>	OX	OX	OX	OX
	150 amp	<b>54W57</b>	OX	OX	OX	OX
GFI Service Outlets	15 amp non-powered, field-wired (208/230V, 460V only)	<b>74M70</b>	OX	OX	OX	OX
	<sup>2</sup> 20 amp non-powered, field-wired (208/230V, 460V, 575V)	<b>67E01</b>	X	X	X	X
		Factory	O	O	O	O
Weatherproof Cover for GFI		<b>10C89</b>	X	X	X	X
<b>ELECTRIC HEAT</b>						
7.5 kW	208/240V-3ph	<b>56W38</b>	X	X		
	460V-3ph	<b>56W39</b>	X	X		
	575V-3ph	<b>56W40</b>	X	X		
15 kW	208/240V-3ph	<b>56W41</b>	X	X	X	X
	460V-3ph	<b>56W42</b>	X	X	X	X
	575V-3ph	<b>56W43</b>	X	X	X	X
22.5 kW	208/240V-3ph	<b>56W44</b>	X	X	X	X
	460V-3ph	<b>56W45</b>	X	X	X	X
	575V-3ph	<b>56W46</b>	X	X	X	X
30 kW	208/240V-3ph	<b>56W47</b>	X	X	X	X
	460V-3ph	<b>56W48</b>	X	X	X	X
	575V-3ph	<b>56W49</b>	X	X	X	X
45 kW	208/240V-3ph	<b>56W50</b>	X	X	X	X
	460V-3ph	<b>56W51</b>	X	X	X	X
	575V-3ph	<b>56W52</b>	X	X	X	X
60 kW	208/240V-3ph	<b>55W02</b>			X	X
	460V-3ph	<b>55W03</b>			X	X
	575V-3ph	<b>55W04</b>			X	X

<sup>1</sup> Lamps operate on 110-230V single-phase power supply. Step-down transformer may be ordered separately for 460V and 575V units. Alternately, 110V power supply may be used to directly power the UVC ballast(s).

<sup>2</sup> Canada requires a minimum 20 amp circuit. Select 20 amp, non-powered, field wired GFI.

NOTE - Catalog numbers shown are for ordering field installed accessories.

OX - Configure To Order (Factory Installed) or Field Installed

O = Configure To Order (Factory Installed)

X = Field Installed

## OPTIONS / ACCESSORIES

Item Description	Catalog Number	Unit Model No				
		092	102	120	150	
<b>ECONOMIZER</b>						
<b>Standard Economizer (Not for Title 24)</b>						
Standard Economizer with Single Temperature Control Downflow or Horizontal Applications - Includes Barometric Relief Dampers and Air Hoods	13U45	X	X	X	X	
<b>Standard Economizer Controls (Not for Title 24)</b>						
Single Enthalpy Control	21Z09	X	X	X	X	
Differential Enthalpy Control (order 2)	21Z09	X	X	X	X	
<b>High Performance Economizer (Approved for California Title 24 Building Standards / AMCA Class 1A Certified)</b>						
High Performance Economizer Downflow or Horizontal Applications - Includes Barometric Relief Dampers and Air Hoods Factory Installed Economizer - Enthalpy control is furnished as standard. Field programmable for Sensible Control without additional hardware Field Installed Economizer - Sensible Sensor is furnished as standard	23G23	OX	OX	OX	OX	
<b>High Performance Economizer Controls</b>						
Single Enthalpy Control	23G26	X	X	X	X	
Differential Enthalpy Control (order 1 for factory; order 2 for field) (Not for Title 24)	23G26	X	X	X	X	
<b>Horizontal Low Profile Barometric Relief Dampers With Exhaust Hood</b>						
Horizontal Low Profile Barometric Relief Dampers With Exhaust Hood	53K04	X	X	X	X	
<b>Economizer Accessories</b>						
WLAN Stick (For High Performance Economizer only)	23K58	X	X	X	X	
<b>OUTDOOR AIR</b>						
<b>Outdoor Air Dampers With Outdoor Air Hood</b>						
Motorized	14G28	X	X	X	X	
Manual	14G29	X	X	X	X	
<b>POWER EXHAUST</b>						
Standard Static	208/230V-3ph	53W44	X	X	X	X
	460V-3ph	53W45	X	X	X	X
	575V-3ph	53W46	X	X	X	X
<b>ROOF CURBS</b>						
<b>Hybrid Roof Curbs, Downflow</b>						
8 in. height		11F54	X	X	X	X
14 in. height		11F55	X	X	X	X
18 in. height		11F56	X	X	X	X
24 in. height		11F57	X	X	X	X
<b>Adjustable Pitch Curb</b>						
14 in. height		54W50	X	X	X	X
<b>CEILING DIFFUSERS</b>						
Step-Down - Order one	RTD11-95S	13K61	X			
	RTD11-135S	13K62		X	X	
	RTD11-185S	13K63				X
Flush - Order one	FD11-95S	13K56	X			
	FD11-135S	13K57		X	X	
	FD11-185S	13K58				X
Transitions (Supply and Return) - Order one	C1DIFF30B-1	12X65	X			
	C1DIFF31B-1	12X66		X	X	
	C1DIFF32B-1	12X67				X

NOTE - Catalog numbers shown are for ordering field installed accessories.

OX - Configure To Order (Factory Installed) or Field Installed

O = Configure To Order (Factory Installed)

X = Field Installed

## SPECIFICATIONS

General Data		Nominal Tonnage	7.5 Ton	8.5 Ton	10 Ton	12.5 Ton
		<b>Model Number</b>	<b>KCC092S4M</b>	<b>KCC102S4M</b>	<b>KCC120S4M</b>	<b>KCC150S4M</b>
		<b>Efficiency Type</b>	<b>Standard</b>	<b>Standard</b>	<b>Standard</b>	<b>Standard</b>
		<b>Blower Type</b>	MSAV® Multi-Stage Air Volume	MSAV® Multi-Stage Air Volume	MSAV® Multi-Stage Air Volume	MSAV® Multi-Stage Air Volume
<b>Cooling Performance</b>	Gross Cooling Capacity - Btuh		87,800	99,600	118,000	143,000
	<sup>1</sup> Net Cooling Capacity - Btuh		86,000	97,000	115,000	138,000
	<sup>1</sup> AHRI Rated Air Flow - cfm		2400	2800	3200	3800
	Total Unit Power - kW		7.7	8.7	10.3	12.6
	<sup>1</sup> EER (Btuh/Watt)		11.2	11.2	11.2	11.0
	<sup>1</sup> IEER (Btuh/Watt)		14.8	14.8	14.8	14.2
<b>Refrigerant Charge</b>	<b>Refrigerant Type</b>		R-410A	R-410A	R-410A	R-410A
	Environ™ Coil System	Circuit 1	5 lbs. 5 oz.	5 lbs. 5 oz.	5 lbs. 5 oz.	7 lbs. 0 oz.
		Circuit 2	3 lbs. 12 oz.	3 lbs. 10 oz.	5 lbs. 4 oz.	6 lbs. 15 oz.
	Fin/Tube Coil System	Circuit 1	9 lbs. 4 oz.	10 lbs. 3 oz.	10 lbs. 0 oz.	12 lbs. 10 oz.
		Circuit 2	6 lbs. 0 oz.	5 lbs. 14 oz.	10 lbs. 8 oz.	12 lbs. 8 oz.
	Conventional Fin/Tube with Reheat Option	Circuit 1	9 lbs. 13 oz.	10 lbs. 12 oz.	10 lbs. 9 oz.	13 lbs. 0 oz.
		Circuit 2	6 lbs. 0 oz.	5 lbs. 14 oz.	10 lbs. 8 oz.	12 lbs. 8 oz.
<b>Electric Heat Available - See page 16</b>			7.5, 15, 22.5, 30 & 45 KW			15, 22.5, 30, 45 & 60 KW
<b>Compressor Type (number)</b>			(1) Two-Stage Scroll, (1) Single-Stage Scroll			
<b>Outdoor Coils</b>	Net face area (total) - sq. ft.		20.5	20.5	28.0	28.0
<b>Environ (Fin/Tube)</b>	Number of rows		1 (2)	1 (2)	1 (2)	1 (3)
	Fins per inch		23 (20)	23 (20)	23 (20)	23 (20)
<b>Outdoor Coil Fans</b>	Motor - (No.) hp		(2) 1/3	(2) 1/3	(2) 1/2	(2) 1/2
	Motor rpm		1075	1075	1075	1075
	Total Motor watts		740	740	1050	1050
	Diameter - (No.) in.		(2) 24	(2) 24	(2) 24	(2) 24
	Number of blades		3	3	3	3
	Total Air volume - cfm		8800	8800	9700	9700
<b>Indoor Coils</b>	Net face area (total) - sq. ft.		13.54	13.54	13.54	13.54
	Tube diameter - in.		3/8	3/8	3/8	3/8
	Number of rows		3	3	4	4
	Fins per inch		14	14	14	14
	Drain connection - Number and size		(1) 1 in. NPT coupling			
Expansion device type		Balanced Port Thermostatic Expansion Valve (removable power element)				
<sup>2</sup> <b>Indoor Blower and Drive Selection</b>	Nominal motor output		2 hp, 3 hp, 5 hp			
	Maximum usable motor output (US)		2.3 hp, 3.45 hp, 5.75 hp			
	Motor - Drive kit number		<b>2 hp</b> <b>Kit 1</b> 590-890 rpm <b>Kit 2</b> 800-1105 rpm <b>Kit 3</b> 795-1195 rpm <b>3 hp</b> <b>Kit 4</b> 730-970 rpm <b>Kit 5</b> 940-1200 rpm <b>Kit 6</b> 1015-1300 rpm <b>5 hp</b> <b>Kit 10</b> 900-1135 rpm <b>Kit 11</b> 1040-1315 rpm <b>Kit 12</b> 1125-1425 rpm			
	Blower wheel nominal diameter x width - in.		(1) 15 X 15			
<b>Filters</b>	Type of filter		MERV 4, Disposable			
	Number and size - in.		(4) 20 x 25 x 2			
<b>Electrical characteristics</b>			208/230V, 460V or 575V - 60 hertz - 3 phase			

NOTE - Net capacity includes evaporator blower motor heat deduction. Gross capacity does not include evaporator blower motor heat deduction.

<sup>1</sup> AHRI Certified to AHRI Standard 340/360; 95°F outdoor air temperature and 80°F db/67°F wb entering evaporator air; minimum external duct static pressure.

<sup>2</sup> Using total air volume and system static pressure requirements determine from blower performance tables rpm and motor output required. Maximum usable output of motors furnished are shown. In Canada, nominal motor output is also maximum usable motor output. If motors of comparable output are used, be sure to keep within the service factor limitations outlined on the motor nameplate.

# RATINGS

NOTE – For Temperatures and Capacities not shown in tables, see bulletin – Cooling Unit Rating Table Correction Factor Data in Miscellaneous Engineering Data section.

## 7.5 TON - KCC092S4M (1 COMPRESSOR - PART LOAD)

Entering Wet Bulb Temperature	Total Air Volume	Outdoor Air Temperature Entering Outdoor Coil																			
		65°F					75°F					85°F					95°F				
		Total Cool Cap.	Comp. Motor Input	Sensible To Total Ratio (S/T)			Total Cool Cap.	Comp. Motor Input	Sensible To Total Ratio (S/T)			Total Cool Cap.	Comp. Motor Input	Sensible To Total Ratio (S/T)			Total Cool Cap.	Comp. Motor Input	Sensible To Total Ratio (S/T)		
				Dry Bulb					Dry Bulb					Dry Bulb					Dry Bulb		
cfm	kBtuh	kW	75°F	80°F	85°F	kBtuh	kW	75°F	80°F	85°F	kBtuh	kW	75°F	80°F	85°F	kBtuh	kW	75°F	80°F	85°F	
63°F	1600	49.2	1.72	0.76	0.92	1	46.4	2.01	0.77	0.94	1	43.3	2.33	0.79	0.97	1	39.9	2.7	0.81	1	1
	1980	51.8	1.71	0.82	1	1	49	1.99	0.83	1	1	46	2.32	0.85	1	1	42.7	2.68	0.88	1	1
	2360	54.4	1.69	0.87	1	1	51.6	1.98	0.89	1	1	48.4	2.31	0.92	1	1	44.9	2.68	0.96	1	1
67°F	1600	52.1	1.71	0.6	0.74	0.88	49.2	1.99	0.6	0.75	0.9	45.9	2.32	0.6	0.77	0.93	42.4	2.69	0.61	0.78	0.97
	1980	54.6	1.69	0.63	0.8	0.97	51.5	1.98	0.63	0.81	0.99	48.1	2.31	0.64	0.83	1	44.2	2.68	0.66	0.86	1
71°F	2360	56.4	1.68	0.66	0.85	1	53.2	1.97	0.67	0.87	1	49.5	2.3	0.68	0.9	1	45.7	2.67	0.7	0.94	1
	1600	54.8	1.69	0.44	0.58	0.72	51.8	1.98	0.43	0.59	0.73	48.5	2.31	0.43	0.59	0.74	44.8	2.68	0.42	0.6	0.76
	1980	57.5	1.67	0.46	0.62	0.77	54.3	1.97	0.45	0.63	0.79	50.7	2.29	0.45	0.64	0.81	46.9	2.67	0.45	0.65	0.84
	2360	59.4	1.66	0.47	0.66	0.83	56.1	1.96	0.47	0.66	0.85	52.4	2.29	0.47	0.68	0.88	48.3	2.66	0.47	0.69	0.91

## 7.5 TON - KCC092S4M (2 COMPRESSORS - PART LOAD / FULL LOAD)

Entering Wet Bulb Temperature	Total Air Volume	Outdoor Air Temperature Entering Outdoor Coil																			
		85°F					95°F					105°F					115°F				
		Total Cool Cap.	Comp. Motor Input	Sensible To Total Ratio (S/T)			Total Cool Cap.	Comp. Motor Input	Sensible To Total Ratio (S/T)			Total Cool Cap.	Comp. Motor Input	Sensible To Total Ratio (S/T)			Total Cool Cap.	Comp. Motor Input	Sensible To Total Ratio (S/T)		
				Dry Bulb					Dry Bulb					Dry Bulb					Dry Bulb		
cfm	kBtuh	kW	75°F	80°F	85°F	kBtuh	kW	75°F	80°F	85°F	kBtuh	kW	75°F	80°F	85°F	kBtuh	kW	75°F	80°F	85°F	
63°F	1800	71.4	4.43	0.66	0.79	0.9	65.9	5.09	0.66	0.81	0.92	60.1	5.83	0.67	0.82	0.95	54.1	6.65	0.69	0.85	0.99
	2250	76.7	4.42	0.7	0.85	0.97	71.1	5.09	0.71	0.87	0.99	65	5.83	0.73	0.89	1	58.5	6.65	0.75	0.92	1
	2700	81	4.42	0.75	0.9	1	75.1	5.08	0.78	0.92	1	68.6	5.82	0.8	0.96	1	61.8	6.65	0.82	0.99	1
67°F	1800	76.6	4.42	0.52	0.65	0.76	71	5.09	0.52	0.64	0.77	64.7	5.82	0.52	0.65	0.79	58	6.65	0.51	0.66	0.81
	2250	81.6	4.41	0.56	0.68	0.82	75.3	5.07	0.55	0.69	0.84	68.6	5.82	0.56	0.72	0.86	61.4	6.64	0.55	0.74	0.89
	2700	84.8	4.41	0.57	0.73	0.87	78.4	5.07	0.58	0.75	0.89	71.5	5.81	0.58	0.77	0.92	64.2	6.64	0.59	0.8	0.96
71°F	1800	81.8	4.41	0.39	0.51	0.62	75.8	5.07	0.39	0.51	0.62	69.4	5.82	0.36	0.5	0.63	62.6	6.63	0.35	0.51	0.64
	2250	86.8	4.4	0.41	0.54	0.67	80.5	5.07	0.4	0.54	0.67	73.7	5.81	0.39	0.55	0.68	66.6	6.64	0.36	0.54	0.71
	2700	90.7	4.39	0.41	0.57	0.71	84	5.06	0.42	0.57	0.73	76.9	5.81	0.4	0.58	0.75	69.2	6.64	0.4	0.59	0.78

## 7.5 TON - KCC092S4M (2 COMPRESSORS - FULL LOAD)

Entering Wet Bulb Temperature	Total Air Volume	Outdoor Air Temperature Entering Outdoor Coil																			
		85°F					95°F					105°F					115°F				
		Total Cool Cap.	Comp. Motor Input	Sensible To Total Ratio (S/T)			Total Cool Cap.	Comp. Motor Input	Sensible To Total Ratio (S/T)			Total Cool Cap.	Comp. Motor Input	Sensible To Total Ratio (S/T)			Total Cool Cap.	Comp. Motor Input	Sensible To Total Ratio (S/T)		
				Dry Bulb					Dry Bulb					Dry Bulb					Dry Bulb		
cfm	kBtuh	kW	75°F	80°F	85°F	kBtuh	kW	75°F	80°F	85°F	kBtuh	kW	75°F	80°F	85°F	kBtuh	kW	75°F	80°F	85°F	
63°F	2400	91.4	5.41	0.69	0.81	0.93	85.8	6.1	0.69	0.82	0.95	80	6.9	0.7	0.84	0.97	73.8	7.81	0.7	0.86	0.99
	3000	97.3	5.46	0.74	0.87	0.99	91.3	6.15	0.74	0.89	1	85.1	6.94	0.76	0.91	1	78.4	7.86	0.78	0.94	1
	3600	101.8	5.5	0.78	0.93	1	95.4	6.19	0.8	0.95	1	88.7	6.98	0.81	0.98	1	81.8	7.89	0.83	1	1
67°F	2400	96.7	5.45	0.54	0.66	0.78	90.4	6.14	0.53	0.68	0.79	84	6.93	0.53	0.69	0.81	77.4	7.84	0.53	0.69	0.83
	3000	101.6	5.5	0.56	0.72	0.84	95.1	6.18	0.58	0.72	0.86	88.4	6.97	0.58	0.75	0.88	81.5	7.89	0.58	0.75	0.91
	3600	105.2	5.54	0.59	0.77	0.9	98.8	6.22	0.61	0.77	0.92	91.8	7.01	0.61	0.79	0.95	84.7	7.92	0.61	0.81	0.98
71°F	2400	102.5	5.51	0.4	0.53	0.65	96.2	6.19	0.39	0.53	0.64	89.7	6.99	0.39	0.53	0.65	82.7	7.9	0.37	0.53	0.67
	3000	108	5.56	0.41	0.56	0.7	101.2	6.25	0.41	0.56	0.71	94.3	7.04	0.41	0.56	0.72	86.7	7.95	0.4	0.57	0.74
	3600	111.8	5.61	0.43	0.59	0.74	104.7	6.29	0.43	0.59	0.76	97.4	7.07	0.43	0.6	0.77	89.4	7.98	0.42	0.62	0.8

# RATINGS

NOTE – For Temperatures and Capacities not shown in tables, see bulletin – Cooling Unit Rating Table Correction Factor Data in Miscellaneous Engineering Data section.

## 8.5 TON - KCC102S4M (1 COMPRESSOR - PART LOAD)

Entering Wet Bulb Temperature	Total Air Volume	Outdoor Air Temperature Entering Outdoor Coil																							
		65°F						75°F						85°F						95°F					
		Total Cool Cap.	Comp. Motor Input	Sensible To Total Ratio (S/T)			Total Cool Cap.	Comp. Motor Input	Sensible To Total Ratio (S/T)			Total Cool Cap.	Comp. Motor Input	Sensible To Total Ratio (S/T)			Total Cool Cap.	Comp. Motor Input	Sensible To Total Ratio (S/T)						
				Dry Bulb					Dry Bulb					Dry Bulb					Dry Bulb						
cfm	kBtuh	kW	75°F	80°F	85°F	kBtuh	kW	75°F	80°F	85°F	kBtuh	kW	75°F	80°F	85°F	kBtuh	kW	75°F	80°F	85°F					
63°F	1800	50.6	1.75	0.79	0.96	1	47.8	2.04	0.8	0.99	1	44.7	2.38	0.82	1	1	41.5	2.75	0.85	1	1				
	2250	53.6	1.73	0.85	1	1	50.9	2.03	0.87	1	1	47.8	2.36	0.9	1	1	44.4	2.74	0.93	1	1				
	2700	56.3	1.72	0.92	1	1	53.4	2.02	0.94	1	1	50.1	2.35	0.97	1	1	46.5	2.73	1	1	1				
67°F	1800	53.6	1.74	0.61	0.77	0.92	50.5	2.03	0.62	0.78	0.95	47.2	2.37	0.62	0.8	0.98	43.4	2.74	0.63	0.82	1				
	2250	56	1.72	0.65	0.83	1	52.8	2.02	0.66	0.85	1	49.1	2.36	0.67	0.88	1	45.2	2.73	0.69	0.91	1				
	2700	57.6	1.71	0.69	0.9	1	54.3	2.01	0.7	0.92	1	50.7	2.35	0.72	0.95	1	46.8	2.73	0.73	0.99	1				
71°F	1800	56.3	1.72	0.45	0.6	0.75	53.3	2.02	0.44	0.61	0.76	49.8	2.35	0.44	0.62	0.78	46	2.73	0.43	0.63	0.8				
	2250	58.9	1.7	0.46	0.65	0.81	55.6	2	0.46	0.65	0.83	52	2.34	0.46	0.67	0.86	48	2.72	0.47	0.68	0.89				
	2700	60.7	1.69	0.49	0.69	0.88	57.3	1.99	0.49	0.7	0.9	53.4	2.33	0.49	0.71	0.93	49.3	2.72	0.49	0.73	0.97				

## 8.5 TON - KCC102S4M (2 COMPRESSORS - PART LOAD / FULL LOAD)

Entering Wet Bulb Temperature	Total Air Volume	Outdoor Air Temperature Entering Outdoor Coil																							
		85°F						95°F						105°F						115°F					
		Total Cool Cap.	Comp. Motor Input	Sensible To Total Ratio (S/T)			Total Cool Cap.	Comp. Motor Input	Sensible To Total Ratio (S/T)			Total Cool Cap.	Comp. Motor Input	Sensible To Total Ratio (S/T)			Total Cool Cap.	Comp. Motor Input	Sensible To Total Ratio (S/T)						
				Dry Bulb					Dry Bulb					Dry Bulb					Dry Bulb						
cfm	kBtuh	kW	75°F	80°F	85°F	kBtuh	kW	75°F	80°F	85°F	kBtuh	kW	75°F	80°F	85°F	kBtuh	kW	75°F	80°F	85°F					
63°F	2040	80.5	5.21	0.67	0.79	0.91	74.4	5.94	0.68	0.82	0.93	68	6.77	0.68	0.83	0.96	61.4	7.72	0.7	0.86	0.99				
	2550	85.7	5.21	0.71	0.86	0.98	79.6	5.94	0.72	0.88	1	73.1	6.77	0.74	0.9	1	66.2	7.73	0.77	0.93	1				
	3060	90.3	5.21	0.76	0.91	1	83.9	5.94	0.77	0.93	1	77.1	6.78	0.79	0.96	1	69.9	7.73	0.82	0.99	1				
67°F	2040	85.9	5.21	0.53	0.65	0.77	79.6	5.94	0.53	0.66	0.78	73	6.77	0.52	0.66	0.81	65.7	7.72	0.53	0.68	0.83				
	2550	91.1	5.21	0.56	0.69	0.83	84.4	5.94	0.56	0.7	0.85	77.3	6.77	0.57	0.72	0.87	69.8	7.73	0.56	0.73	0.9				
	3060	95	5.21	0.58	0.74	0.88	88	5.94	0.59	0.76	0.9	80.6	6.77	0.59	0.77	0.93	72.5	7.73	0.6	0.8	0.97				
71°F	2040	91.3	5.2	0.39	0.52	0.63	84.8	5.93	0.38	0.51	0.63	78	6.77	0.37	0.52	0.64	70.6	7.72	0.36	0.52	0.66				
	2550	96.9	5.2	0.42	0.54	0.67	89.9	5.94	0.4	0.55	0.68	82.4	6.77	0.4	0.56	0.7	74.5	7.73	0.38	0.56	0.71				
	3060	100.8	5.21	0.42	0.57	0.72	93.4	5.94	0.42	0.58	0.74	85.6	6.78	0.4	0.59	0.75	77.1	7.73	0.41	0.6	0.78				

## 8.5 TON - KCC102S4M (2 COMPRESSORS - FULL LOAD)

Entering Wet Bulb Temperature	Total Air Volume	Outdoor Air Temperature Entering Outdoor Coil																							
		85°F						95°F						105°F						115°F					
		Total Cool Cap.	Comp. Motor Input	Sensible To Total Ratio (S/T)			Total Cool Cap.	Comp. Motor Input	Sensible To Total Ratio (S/T)			Total Cool Cap.	Comp. Motor Input	Sensible To Total Ratio (S/T)			Total Cool Cap.	Comp. Motor Input	Sensible To Total Ratio (S/T)						
				Dry Bulb					Dry Bulb					Dry Bulb					Dry Bulb						
cfm	kBtuh	kW	75°F	80°F	85°F	kBtuh	kW	75°F	80°F	85°F	kBtuh	kW	75°F	80°F	85°F	kBtuh	kW	75°F	80°F	85°F					
63°F	2720	100.3	6.24	0.7	0.82	0.94	94.2	7.02	0.71	0.84	0.95	88	7.93	0.71	0.85	0.98	81.2	8.98	0.72	0.87	1				
	3400	106.8	6.3	0.74	0.88	1	100.3	7.07	0.76	0.9	1	93.5	7.98	0.77	0.92	1	86.2	9.03	0.79	0.95	1				
	4080	111.7	6.35	0.78	0.94	1	104.8	7.11	0.81	0.96	1	97.6	8.01	0.82	0.98	1	90.1	9.07	0.85	1	1				
67°F	2720	106.6	6.3	0.54	0.67	0.8	99.9	7.07	0.54	0.68	0.81	92.8	7.97	0.55	0.69	0.82	85	9.01	0.54	0.71	0.84				
	3400	112	6.34	0.58	0.72	0.85	104.7	7.11	0.58	0.73	0.87	97	8.01	0.59	0.75	0.89	89	9.06	0.59	0.79	0.92				
	4080	115.8	6.38	0.61	0.77	0.91	108.2	7.15	0.61	0.8	0.93	100.6	8.05	0.61	0.8	0.96	92.6	9.09	0.63	0.82	0.99				
71°F	2720	113.1	6.35	0.4	0.53	0.66	106.1	7.12	0.4	0.53	0.66	98.8	8.02	0.39	0.54	0.67	90.9	9.07	0.38	0.53	0.68				
	3400	118.8	6.41	0.42	0.57	0.7	111.2	7.17	0.42	0.58	0.71	103.2	8.07	0.42	0.58	0.73	94.9	9.12	0.41	0.58	0.75				
	4080	122.8	6.45	0.43	0.59	0.76	114.7	7.21	0.43	0.6	0.76	106.5	8.1	0.44	0.61	0.79	97.5	9.15	0.42	0.61	0.81				

# RATINGS

NOTE – For Temperatures and Capacities not shown in tables, see bulletin – Cooling Unit Rating Table Correction Factor Data in Miscellaneous Engineering Data section.

## 10 TON - KCC120S4M (1 COMPRESSOR - PART LOAD)

Entering Wet Bulb Temperature	Total Air Volume	Outdoor Air Temperature Entering Outdoor Coil																							
		65°F						75°F						85°F						95°F					
		Total Cool Cap.	Comp. Motor Input	Sensible To Total Ratio (S/T)			Total Cool Cap.	Comp. Motor Input	Sensible To Total Ratio (S/T)			Total Cool Cap.	Comp. Motor Input	Sensible To Total Ratio (S/T)			Total Cool Cap.	Comp. Motor Input	Sensible To Total Ratio (S/T)						
				Dry Bulb					Dry Bulb					Dry Bulb					Dry Bulb						
cfm	kBtuh	kW	75°F	80°F	85°F	kBtuh	kW	75°F	80°F	85°F	kBtuh	kW	75°F	80°F	85°F	kBtuh	kW	75°F	80°F	85°F					
63°F	2110	52.1	1.78	0.85	1	1	49.4	2.07	0.87	1	1	46.4	2.4	0.89	1	1	43.1	2.77	0.92	1	1				
	2640	55.5	1.76	0.92	1	1	52.6	2.06	0.94	1	1	49.4	2.39	0.97	1	1	45.8	2.76	0.99	1	1				
	3170	58	1.75	0.99	1	1	55	2.05	1	1	1	51.6	2.38	1	1	1	47.9	2.75	1	1	1				
67°F	2110	54.5	1.77	0.66	0.83	0.99	51.5	2.06	0.67	0.85	1	48	2.39	0.68	0.87	1	44.3	2.76	0.69	0.9	1				
	2640	57	1.76	0.7	0.9	1	53.8	2.05	0.71	0.92	1	50.1	2.39	0.73	0.95	1	46.3	2.76	0.75	0.99	1				
71°F	3170	58.8	1.75	0.75	0.97	1	55.5	2.05	0.76	0.99	1	51.8	2.38	0.78	1	1	47.9	2.75	0.8	1	1				
	2110	57.5	1.76	0.48	0.65	0.81	54.4	2.05	0.48	0.66	0.83	50.8	2.38	0.47	0.67	0.85	46.9	2.76	0.47	0.68	0.88				
	2640	60	1.75	0.5	0.7	0.88	56.6	2.04	0.5	0.71	0.9	52.8	2.38	0.5	0.73	0.93	48.6	2.75	0.51	0.74	0.97				
	3170	61.5	1.74	0.52	0.74	0.95	58.1	2.04	0.52	0.76	0.97	54.1	2.37	0.53	0.78	0.99	49.9	2.75	0.53	0.8	1				

## 10 TON - KCC120S4M (2 COMPRESSORS - PART LOAD / FULL LOAD)

Entering Wet Bulb Temperature	Total Air Volume	Outdoor Air Temperature Entering Outdoor Coil																			
		85°F					95°F					105°F					115°F				
		Total Cool Cap.	Comp. Motor Input	Sensible To Total Ratio (S/T)			Total Cool Cap.	Comp. Motor Input	Sensible To Total Ratio (S/T)			Total Cool Cap.	Comp. Motor Input	Sensible To Total Ratio (S/T)			Total Cool Cap.	Comp. Motor Input	Sensible To Total Ratio (S/T)		
				Dry Bulb					Dry Bulb					Dry Bulb					Dry Bulb		
cfm	kBtuh	kW	75°F	80°F	85°F	kBtuh	kW	75°F	80°F	85°F	kBtuh	kW	75°F	80°F	85°F	kBtuh	kW	75°F	80°F	85°F	
63°F	2400	99	6.04	0.7	0.82	0.92	92.1	6.86	0.7	0.84	0.93	84.9	7.8	0.71	0.85	0.95	77.3	8.9	0.73	0.87	0.98
	3000	105.4	6.07	0.74	0.87	0.97	98.5	6.89	0.76	0.89	0.99	91.2	7.84	0.78	0.91	1	83.2	8.93	0.79	0.93	1
	3600	111.2	6.1	0.79	0.92	1	103.8	6.92	0.8	0.94	1	96	7.87	0.82	0.96	1	87.6	8.96	0.86	0.99	1
67°F	2400	105.8	6.06	0.55	0.67	0.79	98.5	6.89	0.54	0.68	0.81	90.8	7.82	0.54	0.69	0.82	82.5	8.91	0.55	0.71	0.85
	3000	111.8	6.09	0.58	0.72	0.85	104	6.91	0.58	0.73	0.86	95.9	7.85	0.59	0.74	0.88	87	8.93	0.6	0.78	0.91
	3600	116.1	6.1	0.61	0.77	0.89	108.1	6.93	0.61	0.79	0.91	99.7	7.88	0.62	0.8	0.94	90.5	8.96	0.64	0.83	0.97
71°F	2400	113.1	6.09	0.41	0.53	0.65	105.6	6.92	0.41	0.53	0.66	97.7	7.86	0.4	0.53	0.67	89.1	8.95	0.39	0.53	0.68
	3000	119.3	6.12	0.42	0.57	0.7	111.5	6.94	0.43	0.56	0.72	102.9	7.89	0.42	0.58	0.73	93.6	8.97	0.41	0.58	0.76
	3600	123.7	6.13	0.44	0.6	0.75	115.2	6.95	0.43	0.61	0.77	106.5	7.91	0.43	0.61	0.78	97	9	0.43	0.62	0.81

## 10 TON - KCC120S4M (2 COMPRESSORS - FULL LOAD)

Entering Wet Bulb Temperature	Total Air Volume	Outdoor Air Temperature Entering Outdoor Coil																			
		85°F					95°F					105°F					115°F				
		Total Cool Cap.	Comp. Motor Input	Sensible To Total Ratio (S/T)			Total Cool Cap.	Comp. Motor Input	Sensible To Total Ratio (S/T)			Total Cool Cap.	Comp. Motor Input	Sensible To Total Ratio (S/T)			Total Cool Cap.	Comp. Motor Input	Sensible To Total Ratio (S/T)		
				Dry Bulb					Dry Bulb					Dry Bulb					Dry Bulb		
cfm	kBtuh	kW	75°F	80°F	85°F	kBtuh	kW	75°F	80°F	85°F	kBtuh	kW	75°F	80°F	85°F	kBtuh	kW	75°F	80°F	85°F	
63°F	3200	119.7	7.08	0.73	0.85	0.94	112.7	7.95	0.74	0.86	0.96	105.6	8.97	0.75	0.87	0.98	97.6	10.14	0.75	0.89	1
	4000	126.9	7.16	0.77	0.9	1	119.6	8.04	0.78	0.91	1	111.7	9.05	0.81	0.93	1	103.2	10.22	0.82	0.95	1
	4800	132.5	7.22	0.81	0.94	1	124.5	8.09	0.84	0.96	1	116.3	9.1	0.85	0.99	1	107.4	10.29	0.87	1	1
67°F	3200	126.8	7.16	0.57	0.69	0.82	119.1	8.03	0.56	0.7	0.83	111.1	9.03	0.57	0.72	0.85	102.3	10.21	0.57	0.74	0.86
	4000	132.8	7.23	0.61	0.75	0.87	124.5	8.1	0.61	0.77	0.89	116	9.1	0.61	0.79	0.91	106.6	10.27	0.62	0.81	0.93
	4800	136.9	7.28	0.63	0.81	0.92	128.4	8.14	0.65	0.83	0.94	119.4	9.15	0.65	0.83	0.96	110.1	10.33	0.66	0.85	0.99
71°F	3200	133.8	7.24	0.43	0.55	0.68	125.9	8.11	0.41	0.56	0.69	117.5	9.12	0.42	0.55	0.69	108.5	10.31	0.4	0.57	0.72
	4000	140	7.32	0.44	0.59	0.73	131.5	8.18	0.44	0.6	0.75	122.5	9.2	0.42	0.6	0.77	113	10.38	0.42	0.6	0.78
	4800	144.4	7.37	0.46	0.62	0.78	135.6	8.24	0.46	0.63	0.8	126.3	9.25	0.46	0.64	0.82	115.8	10.43	0.44	0.65	0.84

# RATINGS

NOTE – For Temperatures and Capacities not shown in tables, see bulletin – Cooling Unit Rating Table Correction Factor Data in Miscellaneous Engineering Data section.

## 12.5 TON - KCC150S4M (1 COMPRESSOR - PART LOAD)

Entering Wet Bulb Temperature	Total Air Volume	Outdoor Air Temperature Entering Outdoor Coil																							
		65°F						75°F						85°F						95°F					
		Total Cool Cap.	Comp. Motor Input	Sensible To Total Ratio (S/T)			Total Cool Cap.	Comp. Motor Input	Sensible To Total Ratio (S/T)			Total Cool Cap.	Comp. Motor Input	Sensible To Total Ratio (S/T)			Total Cool Cap.	Comp. Motor Input	Sensible To Total Ratio (S/T)						
				Dry Bulb					Dry Bulb					Dry Bulb					Dry Bulb						
cfm	kBtuh	kW	75°F	80°F	85°F	kBtuh	kW	75°F	80°F	85°F	kBtuh	kW	75°F	80°F	85°F	kBtuh	kW	75°F	80°F	85°F					
63°F	2640	64.7	2.16	0.84	1	1	61.5	2.5	0.85	1	1	58.2	2.88	0.87	1	1	54.7	3.33	0.89	1	1				
	3300	68.9	2.14	0.9	1	1	65.5	2.48	0.92	1	1	61.9	2.87	0.95	1	1	58.1	3.31	0.98	1	1				
	3960	72.1	2.13	0.97	1	1	68.5	2.47	0.99	1	1	64.7	2.86	1	1	1	60.6	3.3	1	1	1				
67°F	2640	67.8	2.15	0.65	0.82	0.98	64.2	2.49	0.65	0.83	1	60.5	2.88	0.66	0.85	1	56.3	3.32	0.67	0.87	1				
	3300	70.9	2.14	0.69	0.88	1	67.1	2.48	0.7	0.9	1	63.1	2.87	0.71	0.93	1	58.8	3.31	0.72	0.95	1				
	3960	73.2	2.13	0.73	0.95	1	69.2	2.47	0.74	0.97	1	65.2	2.86	0.75	0.99	1	60.7	3.3	0.77	1	1				
71°F	2640	71.7	2.13	0.47	0.64	0.8	67.9	2.48	0.46	0.65	0.81	63.9	2.86	0.46	0.65	0.83	59.6	3.31	0.46	0.66	0.85				
	3300	74.5	2.12	0.49	0.68	0.86	70.6	2.46	0.49	0.69	0.88	66.2	2.85	0.49	0.7	0.9	61.7	3.3	0.48	0.72	0.93				
	3960	76.5	2.11	0.51	0.72	0.93	72.3	2.45	0.51	0.74	0.95	68.1	2.84	0.51	0.75	0.98	63.6	3.29	0.51	0.77	1				

## 12.5 TON - KCC150S4M (2 COMPRESSORS - PART LOAD / FULL LOAD)

Entering Wet Bulb Temperature	Total Air Volume	Outdoor Air Temperature Entering Outdoor Coil																							
		85°F						95°F						105°F						115°F					
		Total Cool Cap.	Comp. Motor Input	Sensible To Total Ratio (S/T)			Total Cool Cap.	Comp. Motor Input	Sensible To Total Ratio (S/T)			Total Cool Cap.	Comp. Motor Input	Sensible To Total Ratio (S/T)			Total Cool Cap.	Comp. Motor Input	Sensible To Total Ratio (S/T)						
				Dry Bulb					Dry Bulb					Dry Bulb					Dry Bulb						
cfm	kBtuh	kW	75°F	80°F	85°F	kBtuh	kW	75°F	80°F	85°F	kBtuh	kW	75°F	80°F	85°F	kBtuh	kW	75°F	80°F	85°F					
63°F	3000	127.9	7.8	0.69	0.81	0.91	120.6	8.79	0.69	0.82	0.93	112.4	9.92	0.7	0.84	0.94	103.5	11.22	0.71	0.86	0.97				
	3750	135.6	7.86	0.72	0.87	0.97	128	8.85	0.74	0.88	0.99	120	9.99	0.76	0.9	1	111.1	11.29	0.77	0.92	1				
	4500	142.7	7.92	0.77	0.91	1	134.7	8.91	0.79	0.93	1	126.1	10.04	0.81	0.95	1	116.7	11.35	0.83	0.98	1				
67°F	3000	136.6	7.86	0.54	0.66	0.77	128.6	8.84	0.54	0.67	0.79	120	9.97	0.54	0.68	0.81	110.7	11.27	0.54	0.69	0.83				
	3750	144.1	7.91	0.57	0.7	0.84	135.5	8.89	0.57	0.72	0.85	126.5	10.02	0.57	0.72	0.87	116.5	11.31	0.59	0.75	0.89				
	4500	149.7	7.95	0.59	0.75	0.89	140.7	8.93	0.6	0.77	0.9	131.2	10.06	0.61	0.78	0.92	120.6	11.35	0.61	0.81	0.95				
71°F	3000	145.9	7.92	0.41	0.52	0.64	137.4	8.91	0.4	0.53	0.65	128.5	10.04	0.4	0.53	0.65	118.8	11.33	0.39	0.53	0.67				
	3750	153.7	7.98	0.42	0.56	0.68	144.8	8.96	0.41	0.56	0.69	135.1	10.09	0.41	0.57	0.71	124.7	11.37	0.4	0.57	0.73				
	4500	159.4	8.02	0.43	0.59	0.73	149.9	8.99	0.43	0.59	0.75	139.6	10.12	0.42	0.6	0.76	128.7	11.4	0.42	0.61	0.79				

## 12.5 TON - KCC150S4M (2 COMPRESSORS - FULL LOAD)

Entering Wet Bulb Temperature	Total Air Volume	Outdoor Air Temperature Entering Outdoor Coil																							
		85°F						95°F						105°F						115°F					
		Total Cool Cap.	Comp. Motor Input	Sensible To Total Ratio (S/T)			Total Cool Cap.	Comp. Motor Input	Sensible To Total Ratio (S/T)			Total Cool Cap.	Comp. Motor Input	Sensible To Total Ratio (S/T)			Total Cool Cap.	Comp. Motor Input	Sensible To Total Ratio (S/T)						
				Dry Bulb					Dry Bulb					Dry Bulb					Dry Bulb						
cfm	kBtuh	kW	75°F	80°F	85°F	kBtuh	kW	75°F	80°F	85°F	kBtuh	kW	75°F	80°F	85°F	kBtuh	kW	75°F	80°F	85°F					
63°F	4000	148.4	9.02	0.71	0.84	0.94	140.3	10.14	0.72	0.85	0.96	131.6	11.41	0.74	0.87	0.98	122.6	12.89	0.75	0.88	1				
	5000	157	9.12	0.77	0.89	1	148.4	10.23	0.78	0.91	1	139.4	11.5	0.79	0.93	1	129.7	12.97	0.82	0.95	1				
	6000	163.8	9.21	0.81	0.94	1	154.8	10.31	0.83	0.96	1	145.3	11.57	0.85	0.99	1	135	13.03	0.86	1	1				
67°F	4000	156.5	9.11	0.56	0.69	0.81	147.6	10.21	0.55	0.7	0.82	138.1	11.47	0.57	0.71	0.84	127.9	12.91	0.56	0.74	0.86				
	5000	163.9	9.2	0.58	0.74	0.87	154.3	10.3	0.59	0.76	0.88	144.3	11.54	0.6	0.78	0.9	133.7	12.99	0.62	0.79	0.93				
	6000	169.1	9.26	0.61	0.8	0.92	159.4	10.35	0.64	0.81	0.94	149	11.6	0.65	0.82	0.96	138.1	13.05	0.65	0.84	0.99				
71°F	4000	166.3	9.23	0.41	0.54	0.66	156.9	10.33	0.41	0.55	0.68	147	11.58	0.41	0.55	0.7	136.2	13.01	0.41	0.56	0.71				
	5000	173.9	9.32	0.43	0.57	0.72	163.5	10.41	0.42	0.58	0.74	152.9	11.64	0.43	0.6	0.76	141.9	13.09	0.43	0.59	0.78				
	6000	178.6	9.38	0.44	0.61	0.78	168.3	10.46	0.44	0.62	0.79	157.4	11.71	0.45	0.64	0.81	145.7	13.14	0.45	0.65	0.83				

# HUMIDITROL® DEHUMIDIFICATION SYSTEM RATINGS

NOTE - For Temperatures and Capacities not shown in tables, see bulletin - Cooling Unit Rating Table Correction Factor Data in Miscellaneous Engineering Data section.

## 7.5 TON - KCC092S4 HUMIDITROL® DEHUMIDIFICATION OPERATING (PART LOAD)

Entering Wet Bulb Temperature	Total Air Volume	Outdoor Air Temperature Entering Outdoor Coil																				
		65°F						75°F					85°F					95°F				
		Total Cool Cap.	Comp. Motor Input	Sensible To Total Ratio (S/T)			Total Cool Cap.	Comp. Motor Input	Sensible To Total Ratio (S/T)			Total Cool Cap.	Comp. Motor Input	Sensible To Total Ratio (S/T)			Total Cool Cap.	Comp. Motor Input	Sensible To Total Ratio (S/T)			
				Dry Bulb					Dry Bulb					Dry Bulb					Dry Bulb			
cfm	kBtuh	kW	75°F	80°F	85°F	kBtuh	kW	75°F	80°F	85°F	kBtuh	kW	75°F	80°F	85°F	kBtuh	kW	75°F	80°F	85°F		
63°F	1800	45.49	2.73	0.54	0.73	0.78	36.64	3.01	0.51	0.76	0.79	27.11	3.29	0.46	0.80	0.80	17.14	3.55	0.30	0.81	0.81	
	2150	46.37	2.75	0.59	0.78	0.77	37.20	3.05	0.57	0.79	0.78	27.29	3.34	0.54	0.80	0.79	16.55	3.62	0.41	0.81	0.80	
	2500	48.05	2.77	0.64	0.77	0.77	38.12	3.07	0.64	0.79	0.78	27.44	3.38	0.63	0.80	0.79	15.94	3.67	0.60	0.81	0.80	
67°F	1800	50.60	2.76	0.36	0.53	0.70	41.82	3.06	0.28	0.51	0.72	32.22	3.35	0.16	0.48	0.75	21.65	3.62	-0.11	0.40	0.80	
	2150	50.98	2.78	0.38	0.58	0.76	41.46	3.08	0.31	0.57	0.78	30.99	3.38	0.18	0.55	0.79	19.61	3.66	-0.16	0.50	0.80	
	2500	51.42	2.78	0.40	0.63	0.77	41.11	3.09	0.33	0.63	0.78	29.84	3.40	0.19	0.63	0.79	17.68	3.69	-0.21	0.63	0.80	
71°F	1800	55.59	2.79	0.22	0.37	0.52	47.06	3.11	0.12	0.32	0.51	37.69	3.42	-0.04	0.24	0.48	27.38	3.71	-0.32	0.08	0.44	
	2150	56.37	2.80	0.22	0.40	0.57	46.91	3.12	0.11	0.35	0.56	36.64	3.44	-0.07	0.26	0.55	25.28	3.74	-0.45	0.09	0.53	
	2500	56.77	2.80	0.22	0.43	0.61	46.52	3.13	0.11	0.37	0.62	35.29	3.46	-0.09	0.29	0.62	23.31	3.77	-0.55	0.10	0.63	

## 7.5 TON - KCC092S4 HUMIDITROL® DEHUMIDIFICATION OPERATING (FULL LOAD)

Entering Wet Bulb Temperature	Total Air Volume	Outdoor Air Temperature Entering Outdoor Coil																				
		65°F						75°F					85°F					95°F				
		Total Cool Cap.	Comp. Motor Input	Sensible To Total Ratio (S/T)			Total Cool Cap.	Comp. Motor Input	Sensible To Total Ratio (S/T)			Total Cool Cap.	Comp. Motor Input	Sensible To Total Ratio (S/T)			Total Cool Cap.	Comp. Motor Input	Sensible To Total Ratio (S/T)			
				Dry Bulb					Dry Bulb					Dry Bulb					Dry Bulb			
cfm	kBtuh	kW	75°F	80°F	85°F	kBtuh	kW	75°F	80°F	85°F	kBtuh	kW	75°F	80°F	85°F	kBtuh	kW	75°F	80°F	85°F		
63°F	2000	75.32	2.62	0.54	0.68	0.79	63.32	2.87	0.49	0.65	0.78	51.79	3.14	0.44	0.62	0.77	40.95	3.44	0.38	0.59	0.77	
	2450	80.02	2.67	0.56	0.72	0.84	66.73	2.92	0.52	0.70	0.85	54.28	3.20	0.49	0.68	0.85	42.31	3.50	0.42	0.65	0.86	
	2900	84.20	2.71	0.60	0.76	0.90	69.96	2.96	0.58	0.75	0.91	56.37	3.24	0.53	0.74	0.93	43.46	3.55	0.46	0.73	0.94	
67°F	2000	84.59	2.67	0.39	0.53	0.65	71.97	2.92	0.33	0.49	0.64	59.76	3.21	0.27	0.45	0.61	47.95	3.51	0.18	0.40	0.58	
	2450	89.18	2.72	0.41	0.56	0.70	75.19	2.98	0.35	0.53	0.68	61.64	3.26	0.29	0.49	0.66	48.72	3.57	0.21	0.44	0.64	
	2900	92.61	2.76	0.43	0.60	0.74	77.53	3.01	0.37	0.57	0.73	62.99	3.30	0.29	0.53	0.72	49.17	3.61	0.21	0.48	0.71	
71°F	2000	94.12	2.73	0.27	0.39	0.51	81.03	2.99	0.22	0.36	0.48	68.19	3.27	0.13	0.30	0.45	55.69	3.58	0.04	0.24	0.40	
	2450	99.25	2.78	0.27	0.41	0.55	84.53	3.04	0.21	0.36	0.52	70.54	3.32	0.13	0.32	0.49	56.94	3.64	0.01	0.25	0.45	
	2900	102.97	2.82	0.27	0.44	0.59	87.41	3.08	0.22	0.39	0.57	72.23	3.37	0.12	0.34	0.54	57.88	3.68	0.00	0.26	0.50	

## 8.5 TON - KCC102S4 HUMIDITROL® DEHUMIDIFICATION OPERATING (PART LOAD)

Entering Wet Bulb Temperature	Total Air Volume	Outdoor Air Temperature Entering Outdoor Coil																				
		65°F						75°F					85°F					95°F				
		Total Cool Cap.	Comp. Motor Input	Sensible To Total Ratio (S/T)			Total Cool Cap.	Comp. Motor Input	Sensible To Total Ratio (S/T)			Total Cool Cap.	Comp. Motor Input	Sensible To Total Ratio (S/T)			Total Cool Cap.	Comp. Motor Input	Sensible To Total Ratio (S/T)			
				Dry Bulb					Dry Bulb					Dry Bulb					Dry Bulb			
cfm	kBtuh	kW	75°F	80°F	85°F	kBtuh	kW	75°F	80°F	85°F	kBtuh	kW	75°F	80°F	85°F	kBtuh	kW	75°F	80°F	85°F		
63°F	1800	46.66	2.78	0.56	0.75	0.81	35.73	3.05	0.50	0.73	0.77	25.51	3.33	0.44	0.71	0.73	16.21	3.60	0.32	0.66	0.68	
	2400	50.88	2.80	0.66	0.81	0.83	39.05	3.11	0.62	0.78	0.79	27.79	3.41	0.57	0.74	0.75	17.08	3.70	0.52	0.69	0.71	
	3000	54.98	2.82	0.75	0.82	0.84	41.81	3.14	0.73	0.79	0.80	29.24	3.46	0.71	0.75	0.77	17.47	3.77	0.68	0.70	0.72	
67°F	1800	52.78	2.80	0.39	0.57	0.73	41.45	3.10	0.31	0.52	0.71	30.56	3.40	0.20	0.46	0.69	20.12	3.67	0.02	0.38	0.68	
	2400	55.48	2.82	0.44	0.66	0.83	42.65	3.13	0.36	0.63	0.79	30.47	3.44	0.24	0.59	0.75	18.84	3.73	0.03	0.55	0.71	
	3000	57.33	2.82	0.49	0.75	0.84	43.18	3.14	0.41	0.73	0.80	30.12	3.47	0.30	0.71	0.77	17.68	3.77	0.06	0.70	0.72	
71°F	1800	59.20	2.83	0.25	0.41	0.57	47.50	3.15	0.15	0.35	0.52	36.20	3.46	0.02	0.26	0.47	25.37	3.75	-0.17	0.14	0.42	
	2400	62.23	2.84	0.26	0.47	0.66	48.87	3.17	0.15	0.40	0.63	36.17	3.50	0.01	0.31	0.60	24.06	3.80	-0.25	0.19	0.56	
	3000	64.08	2.84	0.26	0.52	0.75	49.61	3.19	0.17	0.46	0.73	35.76	3.52	-0.01	0.38	0.71	22.74	3.84	-0.35	0.25	0.70	

## 8.5 TON - KCC102S4 HUMIDITROL® DEHUMIDIFICATION OPERATING (FULL LOAD)

Entering Wet Bulb Temperature	Total Air Volume	Outdoor Air Temperature Entering Outdoor Coil																				
		65°F						75°F					85°F					95°F				
		Total Cool Cap.	Comp. Motor Input	Sensible To Total Ratio (S/T)			Total Cool Cap.	Comp. Motor Input	Sensible To Total Ratio (S/T)			Total Cool Cap.	Comp. Motor Input	Sensible To Total Ratio (S/T)			Total Cool Cap.	Comp. Motor Input	Sensible To Total Ratio (S/T)			
				Dry Bulb					Dry Bulb					Dry Bulb					Dry Bulb			
cfm	kBtuh	kW	75°F	80°F	85°F	kBtuh	kW	75°F	80°F	85°F	kBtuh	kW	75°F	80°F	85°F	kBtuh	kW	75°F	80°F	85°F		
63°F	2400	84.98	4.88	0.55	0.70	0.83	70.94	5.38	0.54	0.71	0.86	57.40	5.95	0.50	0.74	0.89	44.87	6.61	0.45	0.73	0.94	
	2900	89.69	4.94	0.59	0.75	0.88	74.63	5.45	0.58	0.76	0.92	60.29	6.02	0.55	0.78	0.97	46.69	6.68	0.50	0.80	1.00	
	3400	93.39	5.00	0.62	0.79	0.93	77.18	5.50	0.60	0.81	0.97	61.80	6.07	0.58	0.83	1.00	47.30	6.73	0.54	0.86	1.00	
67°F	2400	95.71	4.96	0.41	0.53	0.66	80.88	5.46	0.36	0.52	0.69	66.58	6.03	0.31	0.50	0.68	53.13	6.69	0.24	0.47	0.69	
	2900	100.58	5.02	0.42	0.56	0.72	84.53	5.52	0.38	0.57	0.73	69.03	6.09	0.33	0.56	0.74	54.17	6.76	0.24	0.53	0.76	
	3400	103.54	5.07	0.42	0.59	0.75	86.21	5.57	0.40	0.59	0.77	69.67	6.14	0.34	0.59	0.79	54.01	6.80	0.24	0.57	0.82	
71°F	2400	106.28	5.04	0.26	0.39	0.52	90.75	5.54	0.22	0.37	0.51	75.95	6.12	0.16	0.32	0.50	61.65	6.78	0.04	0.27	0.46	
	2900	111.62	5.10	0.26	0.41	0.55	94.80	5.61	0.21	0.39	0.55	78.73	6.18	0.13	0.35	0.54	63.43	6.85	0.04	0.29	0.52	
	3400	114.88	5.15	0.27	0.43	0.58	97.18	5.66	0.20	0.41	0.57	80.03	6.23	0.13	0.37	0.58	63.54	6.90	-0.01	0.31	0.57	

# HUMIDITROL® DEHUMIDIFICATION SYSTEM RATINGS

NOTE - For Temperatures and Capacities not shown in tables, see bulletin - Cooling Unit Rating Table Correction Factor Data in Miscellaneous Engineering Data section.

## 10 TON - KCC120S4 HUMIDITROL® DEHUMIDIFICATION OPERATING (PART LOAD)

Entering Wet Bulb Temperature	Total Air Volume	Outdoor Air Temperature Entering Outdoor Coil																							
		65°F						75°F						85°F						95°F					
		Total Cool Cap.	Comp. Motor Input	Sensible To Total Ratio (S/T)			Total Cool Cap.	Comp. Motor Input	Sensible To Total Ratio (S/T)			Total Cool Cap.	Comp. Motor Input	Sensible To Total Ratio (S/T)			Total Cool Cap.	Comp. Motor Input	Sensible To Total Ratio (S/T)						
				Dry Bulb					Dry Bulb					Dry Bulb					Dry Bulb						
cfm	kBtuh	kW	75°F	80°F	85°F	kBtuh	kW	75°F	80°F	85°F	kBtuh	kW	75°F	80°F	85°F	kBtuh	kW	75°F	80°F	85°F					
63°F	2000	46.23	2.76	0.57	0.76	0.94	35.22	2.97	0.49	0.72	0.90	25.42	3.23	0.39	0.66	0.83	16.66	3.52	0.25	0.58	0.74				
	2600	48.82	2.82	0.64	0.89	0.97	36.68	3.04	0.57	0.86	0.93	25.78	3.30	0.48	0.82	0.87	16.38	3.59	0.34	0.75	0.79				
	3200	50.99	2.88	0.72	0.97	0.99	38.26	3.10	0.67	0.92	0.94	26.94	3.36	0.58	0.86	0.89	16.97	3.66	0.47	0.79	0.82				
67°F	2000	52.58	2.81	0.38	0.57	0.75	40.99	3.03	0.30	0.51	0.71	30.33	3.29	0.18	0.43	0.65	20.85	3.58	0.02	0.32	0.58				
	2600	55.38	2.88	0.42	0.65	0.86	42.54	3.10	0.33	0.59	0.84	30.84	3.36	0.20	0.52	0.80	20.54	3.65	0.02	0.41	0.76				
	3200	57.08	2.93	0.46	0.72	0.97	43.26	3.15	0.36	0.67	0.94	30.75	3.40	0.22	0.61	0.89	19.64	3.70	0.01	0.52	0.82				
71°F	2000	59.38	2.88	0.23	0.41	0.58	47.46	3.10	0.12	0.33	0.52	35.91	3.36	0.01	0.24	0.45	25.79	3.65	-0.16	0.12	0.36				
	2600	62.53	2.95	0.22	0.45	0.65	49.04	3.17	0.13	0.37	0.60	36.58	3.43	-0.02	0.27	0.53	25.43	3.72	-0.24	0.14	0.45				
	3200	64.19	3.00	0.23	0.49	0.72	49.72	3.22	0.11	0.41	0.68	36.38	3.47	-0.05	0.31	0.63	24.45	3.77	-0.30	0.16	0.56				

## 10 TON - KCC120S4 HUMIDITROL® DEHUMIDIFICATION OPERATING (FULL LOAD)

Entering Wet Bulb Temperature	Total Air Volume	Outdoor Air Temperature Entering Outdoor Coil																							
		65°F						75°F						85°F						95°F					
		Total Cool Cap.	Comp. Motor Input	Sensible To Total Ratio (S/T)			Total Cool Cap.	Comp. Motor Input	Sensible To Total Ratio (S/T)			Total Cool Cap.	Comp. Motor Input	Sensible To Total Ratio (S/T)			Total Cool Cap.	Comp. Motor Input	Sensible To Total Ratio (S/T)						
				Dry Bulb					Dry Bulb					Dry Bulb					Dry Bulb						
cfm	kBtuh	kW	75°F	80°F	85°F	kBtuh	kW	75°F	80°F	85°F	kBtuh	kW	75°F	80°F	85°F	kBtuh	kW	75°F	80°F	85°F					
63°F	2400	92.90	5.21	0.52	0.66	0.77	81.77	5.77	0.49	0.64	0.77	70.75	6.41	0.47	0.64	0.77	59.67	7.13	0.44	0.63	0.78				
	3000	98.54	5.30	0.56	0.71	0.82	86.15	5.85	0.54	0.70	0.83	74.18	6.50	0.52	0.70	0.84	62.29	7.22	0.49	0.69	0.85				
	3600	102.65	5.37	0.60	0.75	0.87	89.63	5.92	0.59	0.75	0.88	76.78	6.57	0.57	0.75	0.90	63.97	7.30	0.54	0.75	0.93				
67°F	2400	102.43	5.30	0.40	0.51	0.63	91.00	5.85	0.36	0.49	0.62	79.63	6.50	0.32	0.47	0.62	68.23	7.23	0.25	0.43	0.60				
	3000	108.43	5.38	0.40	0.54	0.68	95.59	5.94	0.37	0.53	0.68	82.87	6.58	0.32	0.51	0.67	70.26	7.31	0.27	0.48	0.67				
	3600	112.00	5.45	0.42	0.59	0.73	98.08	6.00	0.39	0.56	0.73	84.35	6.64	0.35	0.55	0.73	70.61	7.37	0.29	0.54	0.73				
71°F	2400	112.91	5.39	0.27	0.39	0.50	100.86	5.95	0.23	0.35	0.48	88.91	6.59	0.19	0.33	0.46	77.20	7.33	0.12	0.28	0.43				
	3000	118.97	5.48	0.27	0.41	0.53	105.84	6.04	0.22	0.37	0.52	92.68	6.68	0.18	0.34	0.49	79.44	7.42	0.10	0.29	0.48				
	3600	122.90	5.55	0.27	0.42	0.57	108.47	6.10	0.23	0.39	0.55	94.07	6.74	0.17	0.37	0.54	80.15	7.48	0.09	0.32	0.53				

## 12.5 TON - KCC150S4 HUMIDITROL® OPERATING (PART LOAD)

Entering Wet Bulb Temperature	Total Air Volume	Outdoor Air Temperature Entering Outdoor Coil																							
		65°F						75°F						85°F						95°F					
		Total Cool Cap.	Comp. Motor Input	Sensible To Total Ratio (S/T)			Total Cool Cap.	Comp. Motor Input	Sensible To Total Ratio (S/T)			Total Cool Cap.	Comp. Motor Input	Sensible To Total Ratio (S/T)			Total Cool Cap.	Comp. Motor Input	Sensible To Total Ratio (S/T)						
				Dry Bulb					Dry Bulb					Dry Bulb					Dry Bulb						
cfm	kBtuh	kW	75°F	80°F	85°F	kBtuh	kW	75°F	80°F	85°F	kBtuh	kW	75°F	80°F	85°F	kBtuh	kW	75°F	80°F	85°F					
63°F	2500	53.94	2.96	0.64	0.84	1.00	44.73	3.39	0.60	0.84	1.00	35.72	3.85	0.53	0.84	1.00	26.46	4.38	0.43	0.85	1.00				
	3200	55.78	2.99	0.71	0.94	1.00	45.64	3.41	0.67	0.96	1.00	35.54	3.88	0.63	0.98	1.00	25.56	4.40	0.53	1.00	1.00				
	3900	56.68	3.01	0.77	1.00	1.00	46.01	3.43	0.75	1.00	1.00	35.50	3.89	0.72	1.00	1.00	24.96	4.42	0.67	1.00	1.00				
67°F	2500	59.37	2.99	0.44	0.63	0.81	50.16	3.40	0.37	0.60	0.80	40.89	3.87	0.27	0.55	0.80	31.38	4.39	0.10	0.48	0.81				
	3200	61.15	3.01	0.47	0.70	0.90	50.91	3.43	0.40	0.67	0.92	40.62	3.89	0.29	0.64	0.94	30.24	4.41	0.10	0.58	0.98				
	3900	61.57	3.02	0.50	0.76	0.98	50.53	3.45	0.43	0.74	1.00	39.25	3.91	0.31	0.73	1.00	28.03	4.43	0.09	0.70	1.00				
71°F	2500	65.20	3.00	0.27	0.45	0.62	55.89	3.43	0.19	0.40	0.59	46.47	3.89	0.05	0.32	0.56	36.93	4.41	-0.14	0.21	0.50				
	3200	67.34	3.03	0.28	0.49	0.69	56.94	3.46	0.18	0.44	0.67	46.44	3.92	0.05	0.36	0.64	35.84	4.44	-0.19	0.24	0.60				
	3900	67.77	3.05	0.28	0.52	0.75	56.44	3.48	0.17	0.47	0.74	45.03	3.94	-0.01	0.39	0.72	33.42	4.45	-0.29	0.25	0.71				

## 12.5 TON - KCC150S4 HUMIDITROL® OPERATING (FULL LOAD)

Entering Wet Bulb Temperature	Total Air Volume	Outdoor Air Temperature Entering Outdoor Coil																							
		65°F						75°F						85°F						95°F					
		Total Cool Cap.	Comp. Motor Input	Sensible To Total Ratio (S/T)			Total Cool Cap.	Comp. Motor Input	Sensible To Total Ratio (S/T)			Total Cool Cap.	Comp. Motor Input	Sensible To Total Ratio (S/T)			Total Cool Cap.	Comp. Motor Input	Sensible To Total Ratio (S/T)						
				Dry Bulb					Dry Bulb					Dry Bulb					Dry Bulb						
cfm	kBtuh	kW	75°F	80°F	85°F	kBtuh	kW	75°F	80°F	85°F	kBtuh	kW	75°F	80°F	85°F	kBtuh	kW	75°F	80°F	85°F					
63°F	2900	118.64	7.08	0.54	0.67	0.78	100.96	7.78	0.51	0.65	0.77	84.30	8.52	0.48	0.63	0.76	68.39	9.34	0.43	0.60	0.75				
	3650	127.41	7.22	0.57	0.73	0.84	108.24	7.93	0.55	0.72	0.83	89.70	8.70	0.52	0.69	0.83	72.32	9.51	0.48	0.68	0.83				
	4400	133.24	7.34	0.62	0.78	0.89	112.34	8.06	0.59	0.76	0.89	93.25	8.82	0.56	0.75	0.90	74.83	9.66	0.53	0.74	0.91				
67°F	2900	132.85	7.23	0.42	0.53	0.64	114.34	7.94	0.38	0.51	0.63	96.54	8.69	0.33	0.47	0.61	79.54	9.53	0.28	0.44	0.59				
	3650	141.98	7.37	0.43	0.57	0.70	121.62	8.09	0.39	0.54	0.69	102.24	8.86	0.35	0.51	0.68	83.52	9.69	0.28	0.48	0.66				
	4400	147.65	7.48	0.45	0.61	0.75	125.78	8.20	0.40	0.59	0.74	104.76	8.98	0.36	0.56	0.73	84.53	9.80	0.30	0.54	0.72				
71°F	2900	148.26	7.39	0.31	0.41	0.52	128.59	8.11	0.26	0.37	0.50	109.65	8.88	0.21	0.34	0.47	91.65	9.72	0.15	0.29	0.43				
	3650	158.02	7.54	0.30	0.43	0.56	136.57	8.26	0.25	0.40	0.53	115.77	9.04	0.20	0.36	0.51	96.36	9.89	0.13	0.31	0.49				
	4400	163.83	7.65	0.30	0.45	0.57	140.89	8.37	0.25	0.42	0.57	118.90	9.16	0.19	0.37	0.55	97.65	10.00	0.11	0.32	0.53				

**KCC092S4M AND KCC102S4M - BASE UNIT**

**BLOWER TABLE INCLUDES RESISTANCE FOR BASE UNIT ONLY (NO HEAT SECTION) WITH DRY INDOOR COIL AND AIR FILTERS IN PLACE. FOR ALL UNITS ADD:**

- 1 – Wet indoor coil air resistance of selected unit.
- 2 – Any factory installed options air resistance (heat section, economizer, etc.)
- 3 – Any field installed accessories air resistance (duct resistance, diffuser, etc.)

Then determine from blower table blower motor output required.

See page 27 for blower motors and drives.

See page 27 for wet coil and option/accessory air resistance data.

**Minimum Air Volume Required For Use With Optional Electric Heat (Maximum Static Pressure - 2.0 in. w.g.)**

7.5 kW, 15 kW, 22.5 kW, 30 kW and 45 kW - 2800 cfm; 60 kW - 4000 cfm

Total Air Volume cfm	Total Static Pressure – in. w.g.																										
	0.2		0.4		0.6		0.8		1.0		1.2		1.4		1.6		1.8		2		2.2		2.4		2.6		
	RPM	BHP	RPM	BHP	RPM	BHP	RPM	BHP	RPM	BHP	RPM	BHP	RPM	BHP	RPM	BHP	RPM	BHP	RPM	BHP	RPM	BHP	RPM	BHP	RPM	BHP	RPM
2000	593	0.11	636	0.07	682	0.10	731	0.22	784	0.60	840	0.96	898	1.26	948	1.38	996	1.47	1045	1.57	1092	1.71	1140	1.92	1188	2.32	
2250	604	0.15	645	0.11	690	0.15	739	0.39	790	0.74	846	1.08	901	1.34	953	1.48	1002	1.57	1052	1.70	1100	1.86	1149	2.09	1197	2.42	
2500	615	0.19	655	0.15	699	0.20	747	0.55	797	0.89	851	1.20	906	1.44	959	1.58	1009	1.68	1059	1.83	1108	2.01	1158	2.26	1206	2.52	
2750	626	0.23	666	0.19	709	0.37	755	0.71	805	1.03	858	1.32	912	1.55	966	1.70	1017	1.81	1067	1.97	1117	2.17	1166	2.44	1215	2.71	
3000	637	0.27	677	0.24	719	0.55	764	0.87	813	1.18	866	1.45	920	1.67	975	1.82	1026	1.96	1076	2.13	1126	2.35	1176	2.63	1225	2.92	
3250	650	0.31	688	0.43	730	0.73	775	1.04	823	1.34	875	1.60	930	1.81	985	1.97	1036	2.12	1086	2.31	1136	2.54	1186	2.83	1235	3.13	
3500	663	0.35	700	0.63	741	0.92	786	1.22	834	1.50	886	1.76	942	1.96	997	2.14	1048	2.31	1097	2.51	1147	2.75	1196	3.04	1245	3.35	
3750	676	0.57	714	0.84	754	1.12	798	1.41	846	1.68	899	1.93	956	2.14	1010	2.32	1060	2.51	1109	2.72	1158	2.98	1207	3.27	1255	3.58	
4000	691	0.79	728	1.05	768	1.33	812	1.61	860	1.88	914	2.12	971	2.34	1023	2.53	1072	2.73	1121	2.95	1169	3.22	1218	3.51	1266	3.83	
4250	706	1.03	743	1.28	783	1.55	827	1.82	876	2.09	931	2.33	987	2.55	1037	2.76	1085	2.97	1133	3.20	1181	3.47	1229	3.76	1277	4.08	
4500	722	1.27	759	1.52	799	1.78	844	2.05	894	2.31	949	2.56	1003	2.79	1052	3.00	1098	3.22	1145	3.46	1193	3.73	1241	4.03	1289	4.34	
4750	739	1.53	776	1.77	817	2.03	862	2.30	913	2.56	968	2.81	1020	3.04	1066	3.27	1112	3.49	1158	3.74	1205	4.01	1253	4.30	1301	4.61	
5000	757	1.79	794	2.04	835	2.30	882	2.56	934	2.83	988	3.08	1036	3.32	1081	3.55	1125	3.78	1171	4.02	1218	4.29	1265	4.59	1312	4.89	

**BLOWER DATA**

**BELT DRIVE - 10 | 12.5 TON**

**KCC120S4M AND KCC150S4M - BASE UNIT**

**BLOWER TABLE INCLUDES RESISTANCE FOR BASE UNIT ONLY (NO HEAT SECTION) WITH DRY INDOOR COIL AND AIR FILTERS IN PLACE. FOR ALL UNITS ADD:**

- 1 – Wet indoor coil air resistance of selected unit.
- 2 – Any factory installed options air resistance (heat section, economizer, etc.)
- 3 – Any field installed accessories air resistance (duct resistance, diffuser, etc.)

Then determine from blower table blower motor output required.

See page 27 for blower motors and drives.

See page 27 for wet coil and option/accessory air resistance data.

**Minimum Air Volume Required For Use With Optional Electric Heat (Maximum Static Pressure - 2.0 in. w.g.)**

15 kW, 22.5 kW, 30 kW and 45 kW - 2800 cfm; 60 kW - 4000 cfm

Total Air Volume cfm	Total Static Pressure – in. w.g.																										
	0.2		0.4		0.6		0.8		1.0		1.2		1.4		1.6		1.8		2.0		2.2		2.4		2.6		
	RPM	BHP	RPM	BHP	RPM	BHP	RPM	BHP	RPM	BHP	RPM	BHP	RPM	BHP	RPM	BHP	RPM	BHP	RPM	BHP	RPM	BHP	RPM	BHP	RPM	BHP	RPM
2000	497	0.25	558	0.44	624	0.6	694	0.74	764	0.85	830	0.99	889	1.16	943	1.34	994	1.52	1045	1.71	1096	1.89	1146	2.08	1197	2.27	
2250	511	0.34	573	0.52	638	0.68	708	0.82	776	0.94	839	1.09	896	1.26	948	1.45	998	1.64	1048	1.83	1098	2.01	1149	2.2	1200	2.4	
2500	527	0.44	589	0.62	654	0.78	723	0.91	789	1.05	850	1.21	904	1.39	955	1.58	1003	1.77	1052	1.96	1101	2.14	1152	2.33	1203	2.53	
2750	545	0.55	606	0.72	672	0.88	740	1.03	804	1.17	861	1.34	914	1.53	962	1.72	1010	1.92	1057	2.10	1105	2.29	1154	2.47	1206	2.68	
3000	564	0.66	626	0.84	692	1.01	759	1.16	819	1.32	874	1.49	924	1.68	971	1.88	1017	2.08	1063	2.26	1110	2.44	1158	2.63	1208	2.83	
3250	585	0.79	648	0.98	714	1.14	778	1.31	836	1.48	887	1.66	935	1.86	981	2.06	1026	2.26	1071	2.45	1117	2.63	1163	2.80	1213	3.00	
3500	607	0.93	672	1.13	737	1.31	798	1.48	852	1.66	901	1.85	948	2.05	993	2.26	1037	2.46	1081	2.65	1125	2.83	1171	3.01	1221	3.21	
3750	632	1.10	698	1.31	762	1.50	819	1.67	869	1.86	915	2.05	961	2.25	1005	2.47	1049	2.68	1092	2.88	1136	3.05	1181	3.24	1231	3.45	
4000	660	1.30	726	1.52	787	1.70	838	1.87	885	2.06	930	2.26	974	2.48	1018	2.71	1062	2.93	1105	3.12	1149	3.30	1194	3.49	1245	3.72	
4250	691	1.53	755	1.75	810	1.91	857	2.07	901	2.27	945	2.50	990	2.74	1034	2.98	1077	3.20	1120	3.39	1163	3.58	1210	3.79	1262	4.03	
4500	724	1.78	783	1.98	831	2.12	874	2.28	917	2.50	962	2.75	1006	3.02	1051	3.27	1094	3.49	1137	3.70	1181	3.89	1228	4.11	1281	4.38	
4750	757	2.05	809	2.20	851	2.33	891	2.51	935	2.76	980	3.05	1025	3.33	1070	3.59	1113	3.82	1156	4.03	1201	4.24	1249	4.47	1303	4.75	
5000	787	2.31	831	2.43	870	2.57	910	2.78	954	3.06	1000	3.38	1046	3.68	1091	3.95	1135	4.19	1178	4.40	1224	4.62	1272	4.86	1325	5.13	
5250	814	2.55	852	2.66	889	2.83	930	3.09	975	3.41	1023	3.76	1070	4.08	1115	4.35	1159	4.59	1203	4.81	1248	5.03	1297	5.27	1350	5.53	
5500	835	2.78	871	2.91	909	3.13	952	3.44	999	3.81	1049	4.18	1096	4.51	1142	4.79	1186	5.03	1229	5.24	1275	5.46	1324	5.69	---	---	
5750	854	3.01	890	3.19	930	3.48	977	3.86	1027	4.27	1078	4.66	1126	4.99	1171	5.26	1214	5.49	1258	5.70	---	---	---	---	---	---	
6000	871	3.26	910	3.53	955	3.90	1006	4.34	1060	4.80	1111	5.19	1158	5.51	---	---	---	---	---	---	---	---	---	---	---	---	
6250	890	3.57	934	3.94	985	4.41	1041	4.91	1096	5.38	---	---	---	---	---	---	---	---	---	---	---	---	---	---	---	---	

## BLOWER DATA

### FACTORY INSTALLED BELT DRIVE KIT SPECIFICATIONS

Nominal hp	Maximum hp	Drive Kit Number	RPM Range
2	2.3	1	590 - 890
2	2.3	2	800 - 1105
2	2.3	3	795 - 1195
3	3.45	4	730 - 970
3	3.45	5	940 - 1200
3	3.45	6	1015 - 1300
5	5.75	10	900 - 1135
5	5.75	11	1040 - 1315
5	5.75	12	1125 - 1425

NOTE - Using total air volume and system static pressure requirements determine from blower performance tables rpm and motor output required. Maximum usable output of motors furnished are shown. In Canada, nominal motor output is also maximum usable motor output. If motors of comparable output are used, be sure to keep within the service factor limitations outlined on the motor nameplate.

NOTE - Motor service factor limit - 1.0.

### POWER EXHAUST FAN PERFORMANCE

Return Air System Static Pressure	Air Volume Exhausted
in. w.g.	cfm
0	3175
0.05	2955
0.10	2685
0.15	2410
0.20	2165
0.25	1920
0.30	1420
0.35	1200

### FACTORY INSTALLED OPTIONS/FIELD INSTALLED ACCESSORY AIR RESISTANCE - in. w.g.

Air Volume cfm	Wet Indoor Coil		Electric Heat	Economizer	Humiditrol® Reheat Coil	Filters			Return Air Adaptor Plate
	092, 102	120, 150				MERV 8	MERV 13	MERV 16	
1750	0.04	0.04	0.03	0.05	0.02	0.01	0.03	0.06	0.00
2000	0.05	0.05	0.03	0.06	0.02	0.01	0.03	0.08	0.00
2250	0.06	0.06	0.04	0.08	0.02	0.01	0.04	0.09	0.00
2500	0.07	0.07	0.04	0.11	0.03	0.01	0.05	0.10	0.00
2750	0.08	0.08	0.05	0.12	0.03	0.02	0.05	0.11	0.00
3000	0.10	0.09	0.06	0.13	0.03	0.02	0.06	0.12	0.02
3250	0.11	0.10	0.06	0.15	0.04	0.02	0.06	0.13	0.02
3500	0.12	0.11	0.09	0.15	0.04	0.03	0.07	0.15	0.04
3750	0.14	0.13	0.09	0.15	0.05	0.03	0.08	0.16	0.07
4000	0.15	0.14	0.09	0.19	0.05	0.04	0.08	0.17	0.09
4250	0.17	0.15	0.13	0.19	0.06	0.04	0.09	0.19	0.11
4500	0.19	0.17	0.14	0.22	0.07	0.04	0.09	0.20	0.12
4750	0.20	0.18	0.17	0.25	0.07	0.05	0.10	0.21	0.16
5000	0.22	0.20	0.20	0.29	0.08	0.06	0.10	0.23	0.18
5250	0.24	0.22	0.22	0.32	0.08	0.06	0.11	0.24	0.19
5500	0.25	0.23	0.25	0.34	0.09	0.07	0.12	0.25	0.22
5750	0.27	0.25	0.31	0.45	0.10	0.07	0.12	0.27	0.25
6000	0.29	0.27	0.33	0.52	0.10	0.08	0.13	0.28	0.27

## BLOWER DATA

### CEILING DIFFUSERS AIR RESISTANCE - in. w.g.

Unit Size	RTD11 Step-Down Diffuser				FD11 Flush Diffuser
	Air Volume cfm	2 Ends Open	1 Side, 2 Ends Open	All Ends & Sides Open	
092 Models	2400	0.21	0.18	0.15	0.14
	2600	0.24	0.21	0.18	0.17
	2800	0.27	0.24	0.21	0.20
	3000	0.32	0.29	0.25	0.25
	3200	0.41	0.37	0.32	0.31
	3400	0.50	0.45	0.39	0.37
	3600	0.61	0.54	0.48	0.44
	3800	0.73	0.63	0.57	0.51
102 & 120 Models	3600	0.36	0.28	0.23	0.15
	3800	0.40	0.32	0.26	0.18
	4000	0.44	0.36	0.29	0.21
	4200	0.49	0.40	0.33	0.24
	4400	0.54	0.44	0.37	0.27
	4600	0.60	0.49	0.42	0.31
	4800	0.65	0.53	0.46	0.35
	5000	0.69	0.58	0.50	0.39
150 Models	5200	0.75	0.62	0.54	0.43
	4200	0.22	0.19	0.16	0.10
	4400	0.28	0.24	0.20	0.12
	4600	0.34	0.29	0.24	0.15
	4800	0.40	0.34	0.29	0.19
	5000	0.46	0.39	0.34	0.23
	5200	0.52	0.44	0.39	0.27
	5400	0.58	0.49	0.43	0.31
5600	0.64	0.54	0.47	0.35	
5800	0.70	0.59	0.51	0.39	

### CEILING DIFFUSER AIR THROW DATA

Model No.	Air Volume cfm	<sup>1</sup> Effective Throw Range	
		RTD11 Step-Down	FD11 Flush
		ft.	ft.
092 Models	2600	24 - 29	19 - 24
	2800	25 - 30	20 - 28
	3000	27 - 33	21 - 29
	3200	28 - 35	22 - 29
	3400	30 - 37	22 - 30
102, 120 Models	3600	25 - 33	22 - 29
	3800	27 - 35	22 - 30
	4000	29 - 37	24 - 33
	4200	32 - 40	26 - 35
	4400	34 - 42	28 - 37
150 Models	5600	39 - 49	28 - 37
	5800	42 - 51	29 - 38
	6000	44 - 54	40 - 50
	6200	45 - 55	42 - 51
	6400	46 - 55	43 - 52
6600	47 - 56	45 - 56	

<sup>1</sup> Throw is the horizontal or vertical distance an air stream travels on leaving the outlet or diffuser before the maximum velocity is reduced to 50 ft. per minute. Four sides open.

**ELECTRICAL/ELECTRIC HEAT DATA**

**7.5 TON**

Model No.		KCC092S4								
<sup>1</sup> Voltage - 60Hz		208/230V - 3 Ph			460V - 3 Ph			575V - 3 Ph		
Compressor 1 (Non-Inverter)	Rated Load Amps	14			6.5			4.9		
	Locked Rotor Amps	93			60			41		
Compressor 2 (Non-Inverter)	Rated Load Amps	9			5.6			3.8		
	Locked Rotor Amps	71			38			36.5		
Outdoor Fan Motors (2)	Full Load Amps (2 Non-ECM)	2.4			1.3			1		
	Total	4.8			2.6			2		
Power Exhaust (1) 0.33 HP	Full Load Amps	2.4			1.3			1		
Service Outlet 115V GFI (amps)		15			15			20		
Indoor Blower Motor	Horsepower	2	3	5	2	3	5	2	3	5
	Full Load Amps	7.5	10.6	16.7	3.4	4.8	7.6	2.7	3.9	6.1
<sup>2</sup> Maximum Overcurrent Protection (MOCP)	Unit Only	50	50	60	25	25	30	15	20	20
	With (1) 0.33 HP Power Exhaust	50	50	60	25	25	30	20	20	25
<sup>3</sup> Minimum Circuit Ampacity (MCA)	Unit Only	39	42	49	20	22	25	15	16	19
	With (1) 0.33 HP Power Exhaust	42	45	52	22	23	26	16	17	20

**ELECTRIC HEAT DATA**

Electric Heat Voltage				208V	240V	208V	240V	208V	240V	480V	480V	480V	600V	600V	600V
<sup>2</sup> Maximum Overcurrent Protection (MOCP)	Unit+ Electric Heat	7.5 kW	7.5 kW	50	50	50	50	60	60	25	25	30	15	20	20
		15 kW	15 kW	50	60	60	60	60	70	30	30	35	25	25	30
		22.5 kW	22.5 kW	70	80	80	90	80	90	40	40	45	35	35	35
		30 kW	30 kW	90	100	100	110	100	125	50	60	60	40	45	45
		45 kW	45 kW	150	150	150	150	50	175	80	80	80	60	60	70
<sup>3</sup> Minimum Circuit Ampacity (MCA)	Unit+ Electric Heat	7.5 kW	7.5 kW	39	39	42	42	49	49	20	22	25	15	16	19
		15 kW	15 kW	49	55	53	59	60	66	27	29	33	22	23	26
		22.5 kW	22.5 kW	69	78	72	81	80	89	39	40	44	31	32	35
		30 kW	30 kW	88	100	92	104	100	112	50	52	55	40	41	44
		45 kW	45 kW	127	145	131	149	139	157	72	74	78	58	60	62
<sup>2</sup> Maximum Overcurrent Protection (MOCP)	Unit+ Electric Heat and (1) 0.33 HP Power Exhaust	7.5 kW	7.5 kW	50	50	50	50	60	60	25	25	30	20	20	25
		15 kW	15 kW	60	60	60	70	70	70	30	35	35	25	25	30
		22.5 kW	22.5 kW	80	90	80	90	90	100	40	45	45	35	35	40
		30 kW	30 kW	100	110	100	110	110	125	60	60	60	45	45	45
		45 kW	45 kW	150	150	150	175	150	175	80	80	80	60	70	70
<sup>3</sup> Minimum Circuit Ampacity (MCA)	Unit+ Electric Heat and (1) 0.33 HP Power Exhaust	7.5 kW	7.5 kW	42	42	45	45	52	52	22	23	26	16	17	20
		15 kW	15 kW	52	58	56	62	63	69	29	31	34	23	25	27
		22.5 kW	22.5 kW	72	81	75	84	83	92	40	42	45	32	34	36
		30 kW	30 kW	91	103	95	107	103	115	51	53	57	41	43	45
		45 kW	45 kW	130	148	134	152	142	160	74	76	79	59	61	64

**ELECTRICAL ACCESSORIES**

Disconnect	7.5 kW	54W56			54W56			54W56		
	15 kW	54W56			54W56			54W56		
	22.5 kW	54W56			54W56			54W56		
	30 kW	54W57			54W56			54W56		
	45 kW	54W57			54W56			54W56		

NOTE - All units have a minimum Short Circuit Current Rating (SCCR) of 5000 amps.

<sup>1</sup> Extremes of operating range are plus and minus 10% of line voltage.

<sup>2</sup> HACR type breaker or fuse.

<sup>3</sup> Refer to National or Canadian Electrical Code manual to determine wire, fuse and disconnect size requirements.

**ELECTRICAL/ELECTRIC HEAT DATA**

**8.5 TON**

Model No.		KCC102S4								
<sup>1</sup> Voltage - 60Hz		208/230V - 3 Ph			460V - 3 Ph			575V - 3 Ph		
Compressor 1 (Non-Inverter)	Rated Load Amps	14			6.5			4.9		
	Locked Rotor Amps	93			60			41		
Compressor 2 (Non-Inverter)	Rated Load Amps	13.1			6.1			4.4		
	Locked Rotor Amps	83.1			41			33		
Outdoor Fan Motors (2)	Full Load Amps (2 Non-ECM)	2.4			1.3			1		
	Total	4.8			2.6			2		
Power Exhaust (1) 0.33 HP	Full Load Amps	2.4			1.3			1		
Service Outlet 115V GFI (amps)		15			15			20		
Indoor Blower Motor	Horsepower	2	3	5	2	3	5	2	3	5
	Full Load Amps	7.5	10.6	16.7	3.4	4.8	7.6	2.7	3.9	6.1
<sup>2</sup> Maximum Overcurrent Protection (MOCP)	Unit Only	50	60	60	25	25	30	20	20	25
	With (1) 0.33 HP Power Exhaust	50	60	70	25	25	30	20	20	25
<sup>3</sup> Minimum Circuit Ampacity (MCA)	Unit Only	43	46	53	21	22	25	16	17	19
	With (1) 0.33 HP Power Exhaust	46	49	56	22	23	27	17	18	20

**ELECTRIC HEAT DATA**

Electric Heat Voltage			208V	240V	208V	240V	208V	240V	480V	480V	480V	600V	600V	600V
<sup>2</sup> Maximum Overcurrent Protection (MOCP)	Unit+ Electric Heat	7.5 kW	50	50	60	60	60	60	25	25	30	20	20	25
		15 kW	50	60	60	60	60	70	30	30	35	25	25	30
		22.5 kW	70	80	80	90	80	90	40	40	45	35	35	35
		30 kW	90	100	100	110	100	125	50	60	60	40	45	45
		45 kW	150	150	150	150	150	175	80	80	80	60	60	70
<sup>3</sup> Minimum Circuit Ampacity (MCA)	Unit+ Electric Heat	7.5 kW	43	43	46	46	53	53	21	22	25	16	17	19
		15 kW	49	55	53	59	60	66	27	29	33	22	23	26
		22.5 kW	69	78	72	81	80	89	39	40	44	31	32	35
		30 kW	88	100	92	104	100	112	50	52	55	40	41	44
		45 kW	127	145	131	149	139	157	72	74	78	58	60	62
<sup>2</sup> Maximum Overcurrent Protection (MOCP)	Unit+ Electric Heat and (1) 0.33 HP Power Exhaust	7.5 kW	50	50	60	60	70	70	25	25	30	20	20	25
		15 kW	60	60	60	70	70	70	30	35	35	25	25	30
		22.5 kW	80	90	80	90	90	100	40	45	45	35	35	40
		30 kW	100	110	100	110	110	125	60	60	60	45	45	45
		45 kW	150	150	150	175	150	175	80	80	80	60	70	70
<sup>3</sup> Minimum Circuit Ampacity (MCA)	Unit+ Electric Heat and (1) 0.33 HP Power Exhaust	7.5 kW	46	46	49	49	56	56	22	23	27	17	18	20
		15 kW	52	58	56	62	63	69	29	31	34	23	25	27
		22.5 kW	72	81	75	84	83	92	40	42	45	32	34	36
		30 kW	91	103	95	107	103	115	51	53	57	41	43	45
		45 kW	130	148	134	152	142	160	74	76	79	59	61	64

**ELECTRICAL ACCESSORIES**

Disconnect	7.5 kW	54W56			54W56			54W56		
	15 kW	54W56			54W56			54W56		
	22.5 kW	54W56			54W56			54W56		
	30 kW	54W57			54W56			54W56		
	45 kW	54W57			54W56			54W56		

NOTE - All units have a minimum Short Circuit Current Rating (SCCR) of 5000 amps.

<sup>1</sup> Extremes of operating range are plus and minus 10% of line voltage.

<sup>2</sup> HACR type breaker or fuse.

<sup>3</sup> Refer to National or Canadian Electrical Code manual to determine wire, fuse and disconnect size requirements.

**ELECTRICAL/ELECTRIC HEAT DATA**

**10 TON**

Model No.		KCC120S4								
<sup>1</sup> Voltage - 60Hz		208/230V - 3 Ph			460V - 3 Ph			575V - 3 Ph		
Compressor 1 (Non-Inverter)	Rated Load Amps	14			6.5			4.9		
	Locked Rotor Amps	93			60			41		
Compressor 2 (Non-Inverter)	Rated Load Amps	16			7.8			5.7		
	Locked Rotor Amps	110			52			38.9		
Outdoor Fan Motors (2)	Full Load Amps (2 Non-ECM)	3			1.5			1.2		
	Total	6			3			2.4		
Power Exhaust (1) 0.33 HP	Full Load Amps	2.4			1.3			1		
Service Outlet 115V GFI (amps)		15			15			20		
Indoor Blower Motor	Horsepower	2	3	5	2	3	5	2	3	5
	Full Load Amps	7.5	10.6	16.7	3.4	4.8	7.6	2.7	3.9	6.1
<sup>2</sup> Maximum Overcurrent Protection (MOCP)	Unit Only	60	60	70	30	30	30	20	20	25
	With (1) 0.33 HP Power Exhaust	60	60	70	30	30	35	20	25	25
<sup>3</sup> Minimum Circuit Ampacity (MCA)	Unit Only	48	51	57	23	25	27	18	19	21
	With (1) 0.33 HP Power Exhaust	50	53	60	24	26	29	19	20	22

**ELECTRIC HEAT DATA**

Electric Heat Voltage				208V	240V	208V	240V	208V	240V	480V	480V	480V	600V	600V	600V
<sup>2</sup> Maximum Overcurrent Protection (MOCP)	Unit+ Electric Heat	15 kW	60	60	60	60	70	70	30	30	35	25	25	30	
		22.5 kW	70	80	80	90	80	90	40	40	45	35	35	35	
		30 kW	90	100	100	110	100	125	50	60	60	40	45	45	
		45 kW	150	150	150	150	150	175	80	80	80	60	60	70	
		60 kW	150	175	150	175	150	175	80	80	90	70	70	70	
<sup>3</sup> Minimum Circuit Ampacity (MCA)	Unit+ Electric Heat	15 kW	49	55	53	59	60	66	27	29	33	22	23	26	
		22.5 kW	69	78	72	81	80	89	39	40	44	31	32	35	
		30 kW	88	100	92	104	100	112	50	52	55	40	41	44	
		45 kW	127	145	131	149	139	157	72	74	78	58	60	62	
		60 kW	135	154	139	158	146	166	77	79	82	62	63	66	
<sup>2</sup> Maximum Overcurrent Protection (MOCP)	Unit+ Electric Heat and (1) 0.33 HP Power Exhaust	15 kW	60	60	60	70	70	70	30	35	35	25	25	30	
		22.5 kW	80	90	80	90	90	100	40	45	45	35	35	40	
		30 kW	100	110	100	110	110	125	60	60	60	45	45	45	
		45 kW	150	150	150	175	150	175	80	80	80	60	70	70	
		60 kW	150	175	150	175	150	175	80	80	90	70	70	70	
<sup>3</sup> Minimum Circuit Ampacity (MCA)	Unit+ Electric Heat and (1) 0.33 HP Power Exhaust	15 kW	52	58	56	62	63	69	29	31	34	23	25	27	
		22.5 kW	72	81	75	84	83	92	40	42	45	32	34	36	
		30 kW	91	103	95	107	103	115	51	53	57	41	43	45	
		45 kW	130	148	134	152	142	160	74	76	79	59	61	64	
		60 kW	138	157	142	161	149	169	79	80	84	63	64	67	

**ELECTRICAL ACCESSORIES**

Disconnect	15 kW	54W56	54W56	54W56
	22.5 kW	54W57	54W56	54W56
	30 kW	54W57	54W56	54W56
	45 kW	54W57	54W56	54W56
	60 kW	Not Available	54W56	54W56

NOTE - All units have a minimum Short Circuit Current Rating (SCCR) of 5000 amps.

<sup>1</sup> Extremes of operating range are plus and minus 10% of line voltage.

<sup>2</sup> HACR type breaker or fuse.

<sup>3</sup> Refer to National or Canadian Electrical Code manual to determine wire, fuse and disconnect size requirements.

**ELECTRICAL/ELECTRIC HEAT DATA**

**12.5 TON**

Model No.		KCC150S4								
<sup>1</sup> Voltage - 60Hz		208/230V - 3 Ph			460V - 3 Ph			575V - 3 Ph		
Compressor 1 (Non-Inverter)	Rated Load Amps	17.6			8.5			6.3		
	Locked Rotor Amps	136			66.1			55.3		
Compressor 2 (Non-Inverter)	Rated Load Amps	22.4			10.6			7.7		
	Locked Rotor Amps	149			75			54		
Outdoor Fan Motors (2)	Full Load Amps (2 Non-ECM)	3			1.5			1.2		
	Total	6			3			2.4		
Power Exhaust (1) 0.33 HP	Full Load Amps	2.4			1.3			1		
Service Outlet 115V GFI (amps)		15			15			20		
Indoor Blower Motor	Horsepower	2	3	5	2	3	5	2	3	5
	Full Load Amps	7.5	10.6	16.7	3.4	4.8	7.6	2.7	3.9	6.1
<sup>2</sup> Maximum Overcurrent Protection (MOCP)	Unit Only	80	80	90	35	40	40	25	25	30
	With (1) 0.33 HP Power Exhaust	80	80	90	40	40	40	25	30	30
<sup>3</sup> Minimum Circuit Ampacity (MCA)	Unit Only	60	63	69	29	30	33	22	23	25
	With (1) 0.33 HP Power Exhaust	62	65	71	30	31	34	23	24	26

**ELECTRIC HEAT DATA**

Electric Heat Voltage			208V	240V	208V	240V	208V	240V	480V	480V	480V	600V	600V	600V
<sup>2</sup> Maximum Overcurrent Protection (MOCP)	Unit+ Electric Heat	15 kW	80	80	80	80	90	90	35	40	40	25	25	30
		22.5 kW	80	80	80	90	90	90	40	40	45	35	35	35
		30 kW	90	100	100	110	100	125	50	60	60	40	45	45
		45 kW	150	150	150	150	150	175	80	80	80	60	60	70
		60 kW	150	175	150	175	150	175	80	80	90	70	70	70
<sup>3</sup> Minimum Circuit Ampacity (MCA)	Unit+ Electric Heat	15 kW	60	60	63	63	69	69	29	30	33	22	23	26
		22.5 kW	69	78	72	81	80	89	39	40	44	31	32	35
		30 kW	88	100	92	104	100	112	50	52	55	40	41	44
		45 kW	127	145	131	149	139	157	72	74	78	58	60	62
		60 kW	135	154	139	158	146	166	77	79	82	62	63	66
<sup>2</sup> Maximum Overcurrent Protection (MOCP)	Unit+ Electric Heat and (1) 0.33 HP Power Exhaust	15 kW	80	80	80	80	90	90	40	40	40	25	30	30
		22.5 kW	80	90	80	90	90	100	40	45	45	35	35	40
		30 kW	100	110	100	110	110	125	60	60	60	45	45	45
		45 kW	150	150	150	175	150	175	80	80	80	60	70	70
		60 kW	150	175	150	175	150	175	80	80	90	70	70	70
<sup>3</sup> Minimum Circuit Ampacity (MCA)	Unit+ Electric Heat and (1) 0.33 HP Power Exhaust	15 kW	62	62	65	65	71	71	30	31	34	23	25	27
		22.5 kW	72	81	75	84	83	92	40	42	45	32	34	36
		30 kW	91	103	95	107	103	115	51	53	57	41	43	45
		45 kW	130	148	134	152	142	160	74	76	79	59	61	64
		60 kW	138	157	142	161	149	169	79	80	84	63	64	67

**ELECTRICAL ACCESSORIES**

Disconnect	15 kW	54W56			54W56			54W56		
	22.5 kW	54W57			54W56			54W56		
	30 kW	54W57			54W56			54W56		
	45 kW	Not Available			54W56			54W56		
	60 kW	Not Available			54W56			54W56		

NOTE - All units have a minimum Short Circuit Current Rating (SCCR) of 5000 amps.

<sup>1</sup> Extremes of operating range are plus and minus 10% of line voltage.

<sup>2</sup> HACR type breaker or fuse.

<sup>3</sup> Refer to National or Canadian Electrical Code manual to determine wire, fuse and disconnect size requirements.

## ELECTRIC HEAT CAPACITIES

Volts Input	7.5 kW			15 kW			22.5 kW			30 kW			45 kW			60 kW		
	kW Input	Btuh Output	No. of Stages	kW Input	Btuh Output	No. of Stages	kW Input	Btuh Output	No. of Stages	kW Input	Btuh Output	No. of Stages	kW Input	Btuh Output	No. of Stages	kW Input	Btuh Output	No. of Stages
208	5.6	19,100	1	11.3	38,600	1	16.9	57,700	2	22.5	76,800	2	33.8	115,300	2	45.0	153,600	2
220	6.3	21,500	1	12.6	43,000	1	18.9	64,500	2	25.2	86,000	2	37.8	129,000	2	50.4	172,000	2
230	6.9	23,600	1	13.8	47,100	1	20.7	70,700	2	27.5	93,900	2	41.3	141,000	2	55.1	188,000	2
240	7.5	25,600	1	15.0	51,200	1	22.5	76,800	2	30.0	102,400	2	45.0	153,600	2	60.0	204,800	2
440	6.9	21,500	1	12.6	43,000	1	18.9	64,500	2	25.2	86,000	2	37.8	129,000	2	50.4	172,000	2
460	6.9	23,600	1	13.8	47,100	1	20.7	70,700	2	27.5	93,900	2	41.3	141,000	2	55.1	188,000	2
480	7.5	25,600	1	15.0	51,200	1	22.5	76,800	2	30.0	102,400	2	45.0	153,600	2	60.0	204,800	2
550	6.3	21,500	1	12.6	43,000	1	18.9	64,500	2	25.2	86,000	2	37.8	129,000	2	50.4	172,000	2
575	6.9	23,600	1	13.8	47,100	1	20.7	70,700	2	27.5	93,900	2	41.3	141,000	2	55.1	188,000	2
600	7.5	25,600	1	15.0	51,200	1	22.5	76,800	2	30.0	102,400	2	45.0	153,600	2	60.0	204,800	2

### FIELD WIRING NOTES

- For use with copper wiring only
- Field wiring not furnished
- All wiring must conform to NEC or CEC and local electrical codes
- For specific wiring information, please refer to the installation instructions

## UNIT CLEARANCES

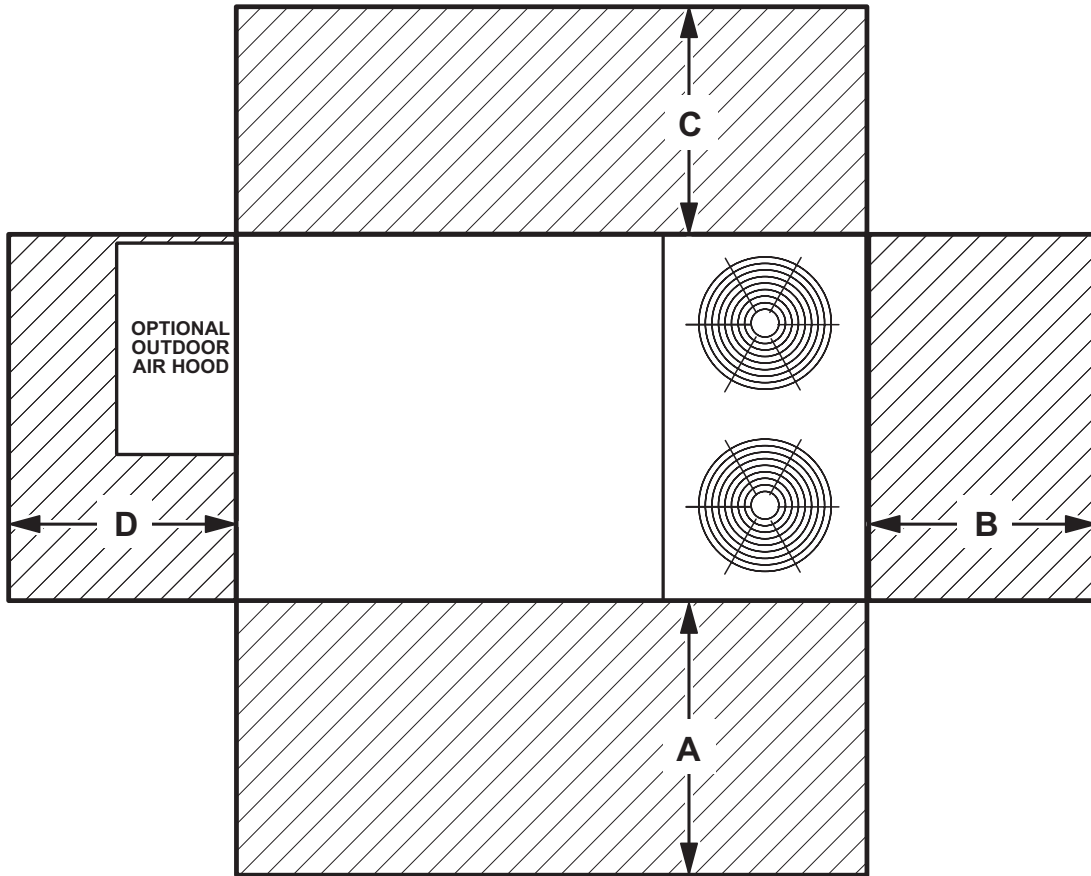

<sup>1</sup> Unit Clearance	A		B		C		D		Top Clearance
	in.	mm	in.	mm	in.	mm	in.	mm	
<b>Service Clearance</b>	60	1524	36	914	36	914	60	1524	Unobstructed
<b>Minimum Operation Clearance</b>	36	914	36	914	36	914	36	914	

NOTE - Entire perimeter of unit base requires support when elevated above the mounting surface.

<sup>1</sup> Service Clearance - Required for removal of serviceable parts.

Minimum Operation Clearance - Required clearance for proper unit operation.

## OUTDOOR SOUND DATA

Unit Model Number	Octave Band Sound Power Levels dBA, re 10 <sup>-12</sup> Watts - Center Frequency - Hz							<sup>1</sup> Sound Rating Number (dBA)
	125	250	500	1000	2000	4000	8000	
092, 102	76	79	84	83	79	73	66	88
120, 150	75	81	87	85	80	73	67	90

Note - The octave sound power data does not include tonal corrections.

<sup>1</sup> Sound Rating Number according to AHRI Standard 270-95 or AHRI Standard 370-2001 (includes pure tone penalty). Sound Rating Number is the overall A-Weighted Sound Power Level, (LWA), dBA (100 Hz to 10,000 Hz).

## WEIGHT DATA

Model Number	Outdoor Coil	Net		Shipping		Outdoor Coil	Net		Shipping	
		lbs.	kg	lbs.	kg		lbs.	kg	lbs.	kg
092S Base Unit	Environ™	870	395	955	433	Fin/Tube	927	421	1012	459
092S Max. Unit	Environ™	1027	466	1112	504	Fin/Tube	1084	492	1169	531
102S Base Unit	Environ™	890	404	975	442	Fin/Tube	947	430	1032	469
102S Max. Unit	Environ™	1047	475	1132	513	Fin/Tube	1104	501	1189	540
120S Base Unit	Environ™	954	432	1039	471	Fin/Tube	1025	465	1110	504
120S Max. Unit	Environ™	1118	507	1203	545	Fin/Tube	1189	540	1274	578
150S Base Unit	Environ™	1004	456	1089	495	Fin/Tube	1084	492	1169	531
150S Max. Unit	Environ™	1154	524	1239	563	Fin/Tube	1234	560	1319	599

NOTE - Max. Unit is the unit with ALL INTERNAL OPTIONS Installed. (Economizer, Standard Static Power Exhaust Fans, Controls, etc.). Does not include accessories EXTERNAL to unit.

## OPTIONS / ACCESSORIES

	Shipping Weight		
	lbs.	kg	
<b>ECONOMIZER / OUTDOOR AIR / POWER EXHAUST</b>			
<b>Economizer</b>			
Economizer Dampers	60	27	
Barometric Relief Dampers (downflow)	8	4	
Barometric Relief Damper Hood (downflow)	25	11	
Outdoor Air Hood (downflow)	23	10	
<b>Outdoor Air Dampers</b>			
Motorized	51	23	
Manual	39	18	
<b>Power Exhaust</b>	31	14	
<b>ELECTRIC HEAT</b>			
7.5 kW	50	23	
15 kW	50	23	
22.5 kW	57	26	
30 kW	57	26	
45 kW	59	27	
60 kW	68	31	
<b>COIL/HAIL GUARDS</b>			
All models	55	25	
<b>ROOF CURBS</b>			
<b>Hybrid Roof Curbs, Downflow</b>			
8 in. height	60	27	
14 in. height	85	39	
18 in. height	100	45	
24 in. height	125	57	
<b>Adjustable Pitch Curb, Downflow</b>			
14 in. height	191	82	
<b>CEILING DIFFUSERS</b>			
Step-Down	RTD11-95S	118	54
	RTD11-135S	135	61
	RTD11-185S	168	76
Flush	FD11-95S	118	54
	FD11-135S	135	61
	FD11-185S	168	76
Transitions	C1DIFF30B-1	30	14
	C1DIFF31B-1	32	15
	C1DIFF32B-1	36	16
<b>HUMIDITROL® DEHUMIDIFICATION SYSTEM</b>			
Humiditrol Dehumidification Option	10	5	

# DIMENSIONS

# UNIT

Model No.	CORNER WEIGHTS														CENTER OF GRAVITY									
	AA				BB				CC				DD				EE				FF			
	Base		Max.		Base		Max.		Base		Max.		Base		Max.		Base		Max.		Base		Max.	
	lbs.	kg	lbs.	kg	lbs.	kg	lbs.	kg	lbs.	kg	lbs.	kg	lbs.	kg	lbs.	kg	in.	mm	in.	mm	in.	mm	in.	mm
092S	223	101	309	141	190	86	259	118	206	94	275	124	250	113	341	154	44-1/2	1130	43-1/2	1105	24-1/2	622	25-1/2	648
102S	228	104	316	143	195	88	262	119	211	96	280	127	254	116	347	157	44-1/2	1130	43-1/2	1105	24-1/2	622	25-1/2	648
120S	243	110	331	150	204	93	273	124	220	100	294	133	271	123	369	167	44	1118	43	1092	24-3/4	629	25-3/4	654
150S	263	119	305	138	222	101	257	117	242	110	280	127	298	135	346	157	44	1118	43	1092	24	610	25	635

Base Unit - The unit with NO OPTIONS.

Max. Unit - The unit with ALL OPTIONS Installed. (Economizer, etc.)

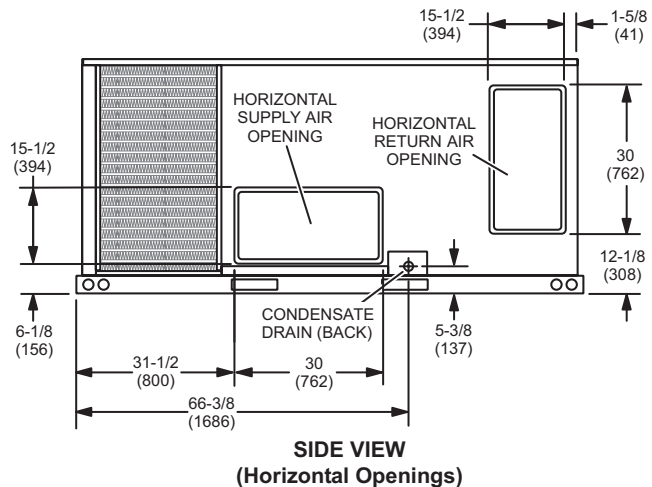
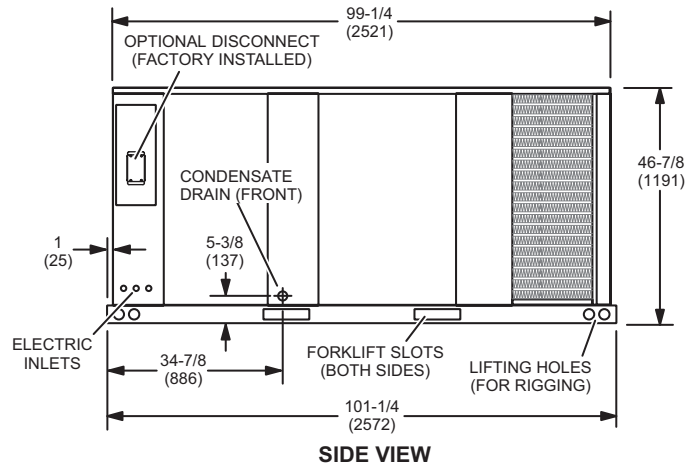
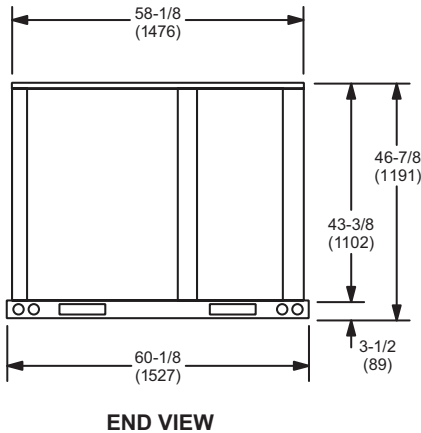
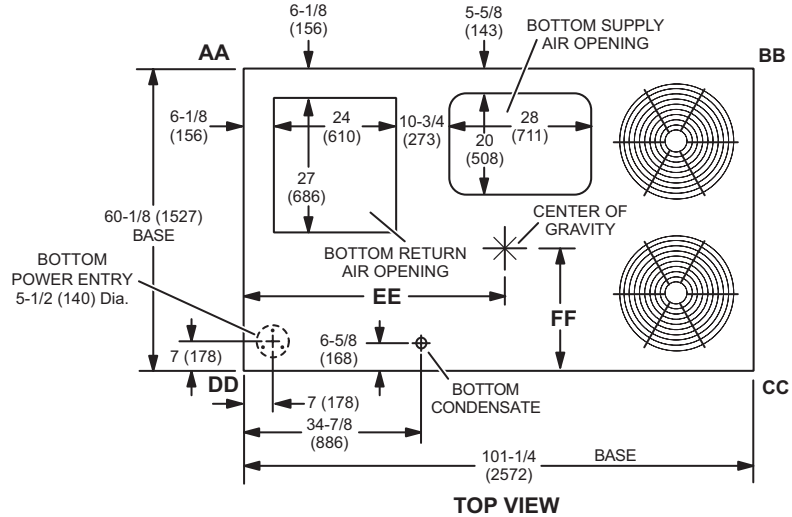

**OUTDOOR AIR HOOD DETAIL**

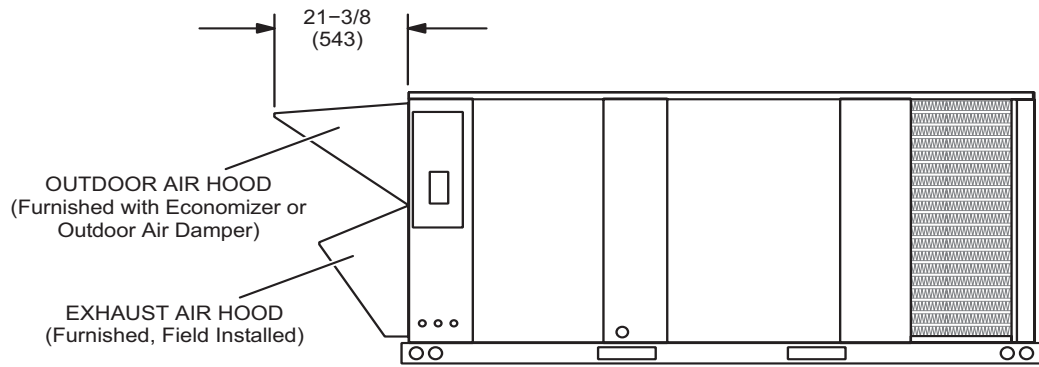

**HORIZONTAL ECONOMIZER APPLICATION**

(With Furnished Barometric Relief Dampers and Optional Horizontal Discharge Kit - Required)

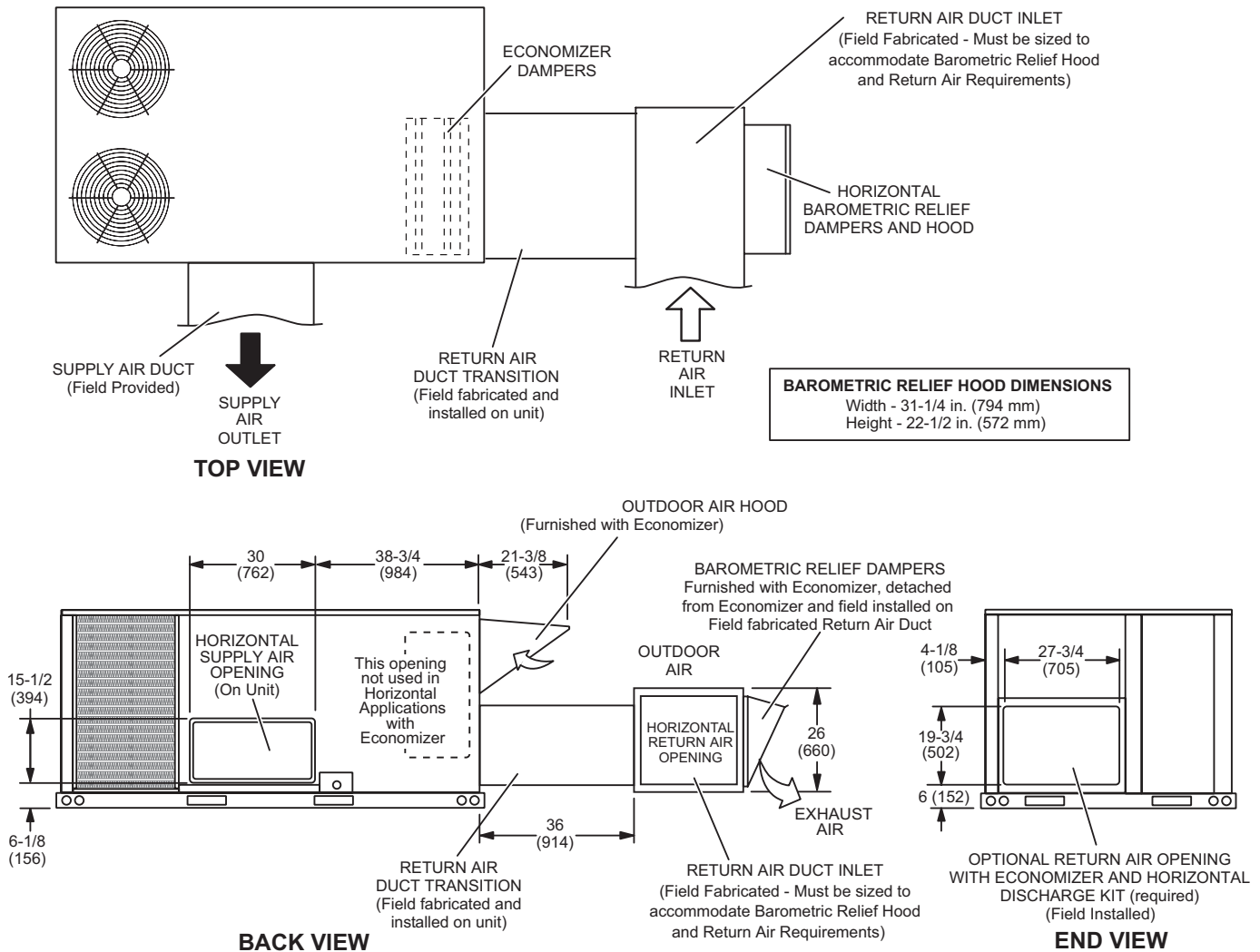

**NOTE** - Return Air Duct and Transition must be supported.

**BAROMETRIC RELIEF DAMPERS (Furnished with Economizer)**

(Field installed in horizontal return air duct adjacent to unit)

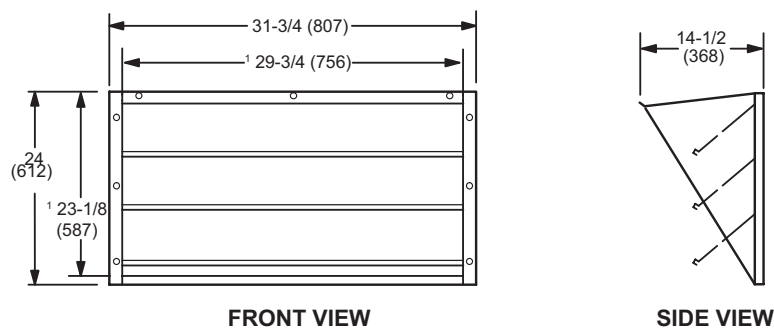

<sup>1</sup> NOTE - Opening size required in return air duct.

**HORIZONTAL ECONOMIZER APPLICATION**

(with Optional Low Profile Horizontal Barometric Relief Dampers and Horizontal Discharge Kit - Required)

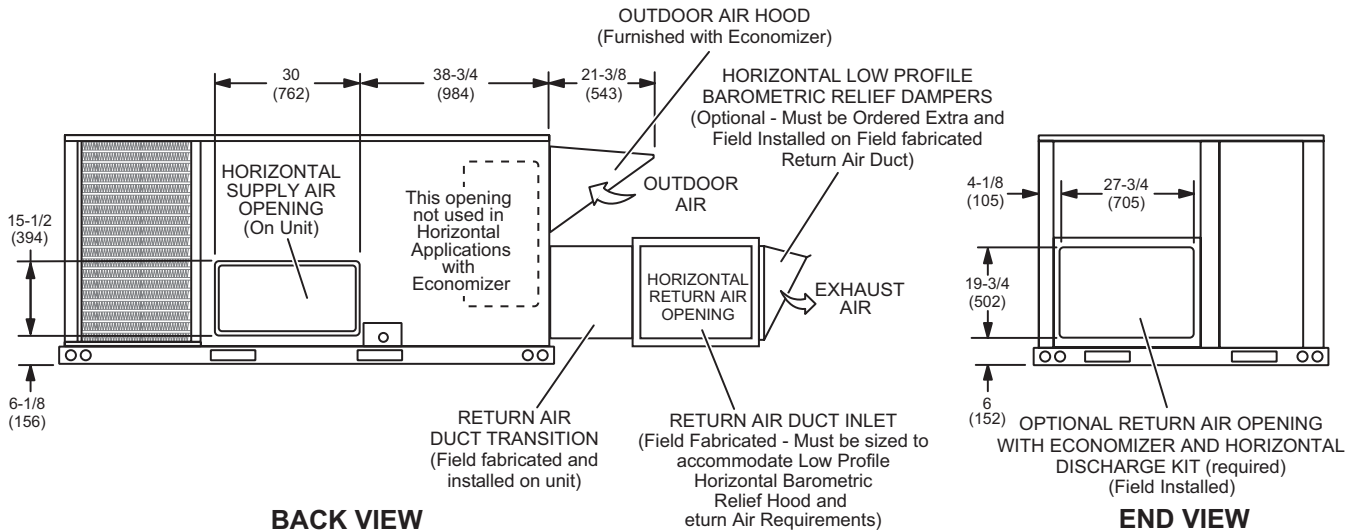
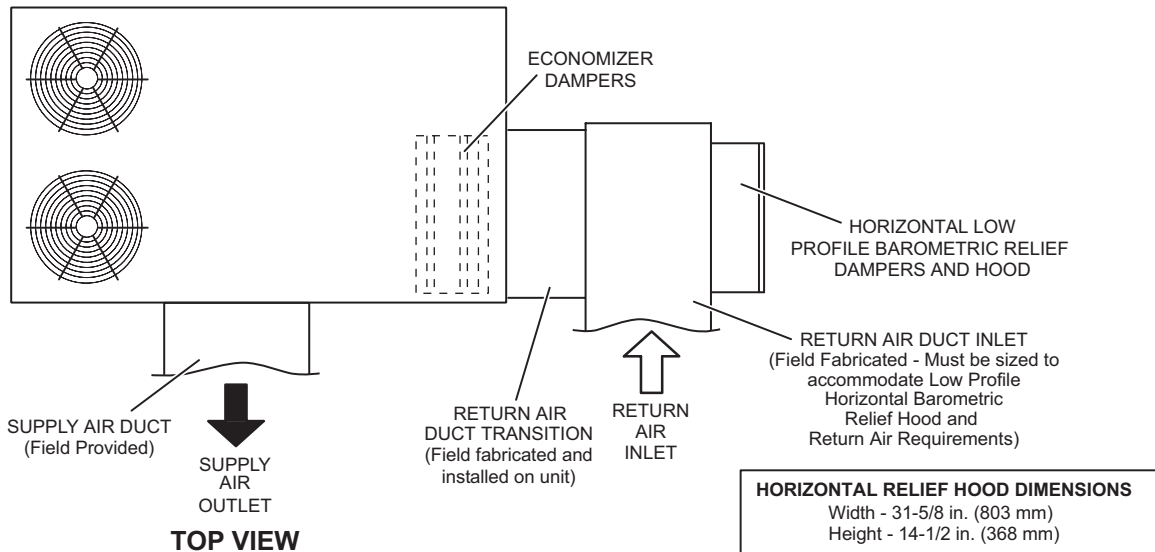

**NOTE** - Return Air Duct and Transition must be supported.

**HORIZONTAL LOW PROFILE BAROMETRIC RELIEF DAMPERS**  
(Field installed in horizontal return air duct adjacent to unit)

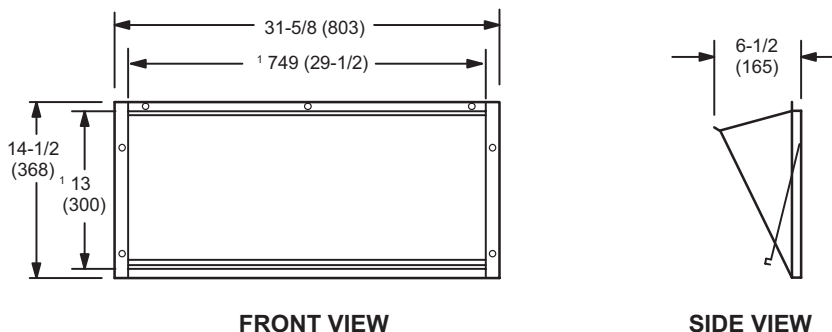

<sup>1</sup> NOTE - Opening size required in return air duct.



**ADJUSTABLE PITCH CURBS - DOUBLE DUCT OPENING**

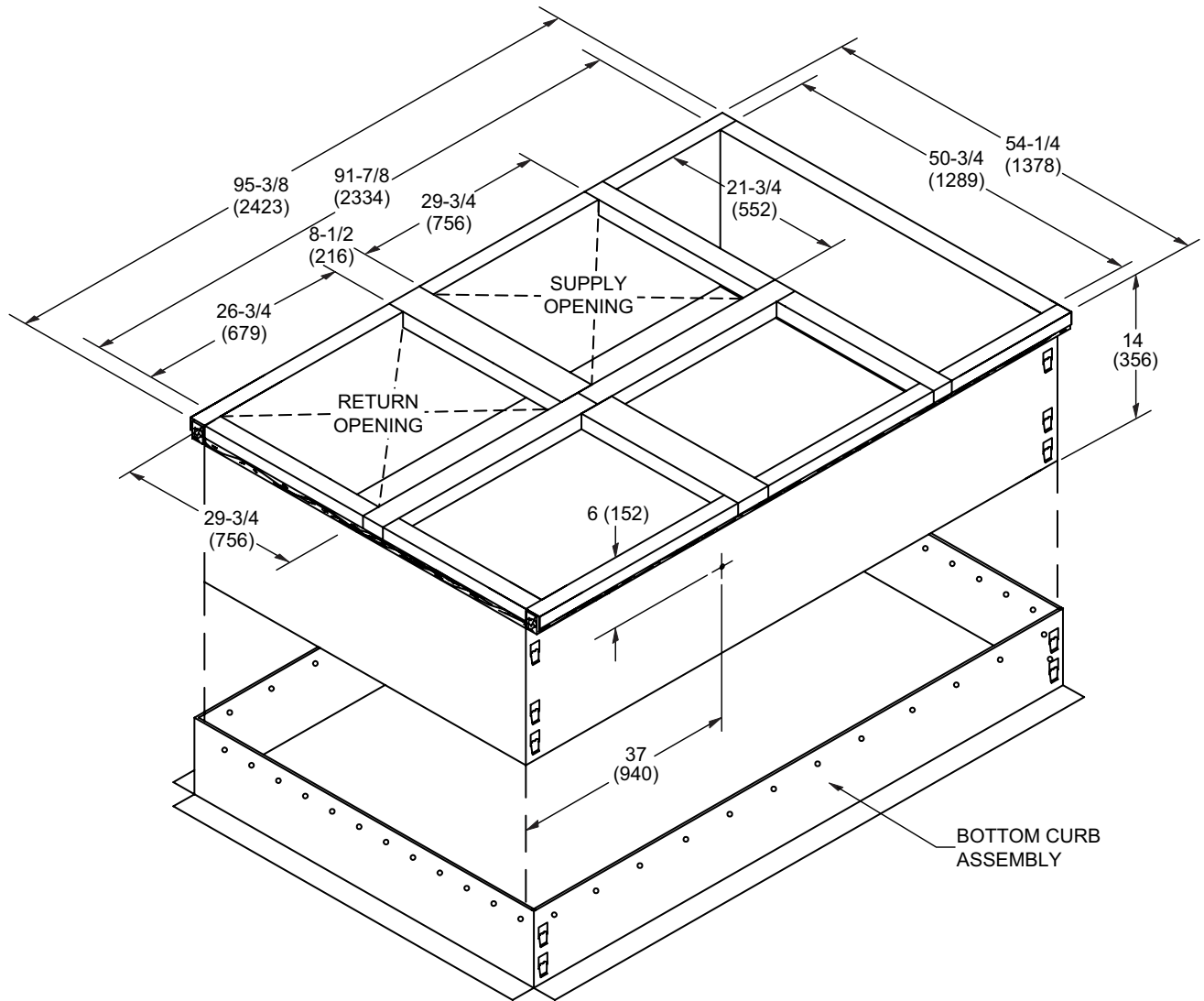

**TYPICAL FLASHING DETAIL FOR ROOF CURB**

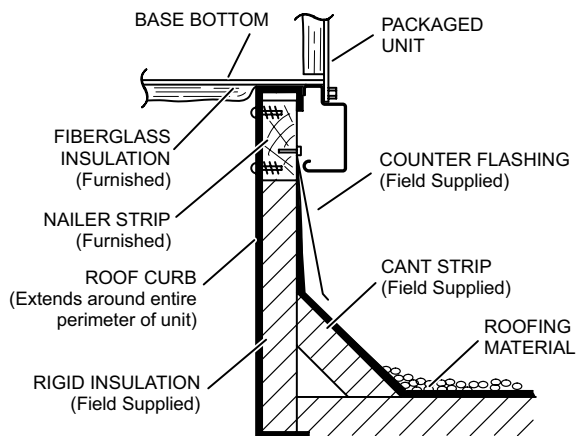

**DETAIL ROOF CURB**

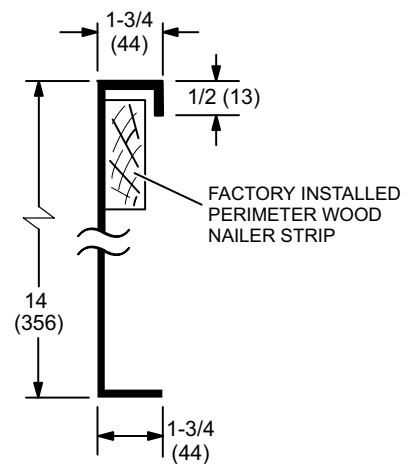

ROOF CURBS WITH SUPPLY & RETURN AIR TRANSITIONS FOR CEILING DIFFUSERS

**C1DIFF30B-1 ROUND TRANSITIONS**  
(for 092 models)

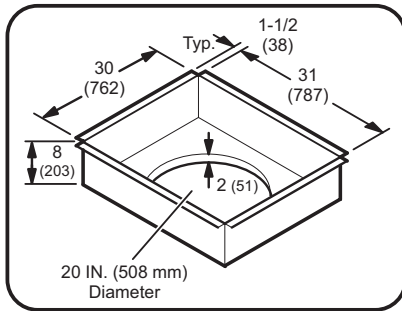

**C1DIFF31B-1 & C1DIFF32B-1 RECTANGULAR TRANSITIONS**  
(for 102 thru 150 models)

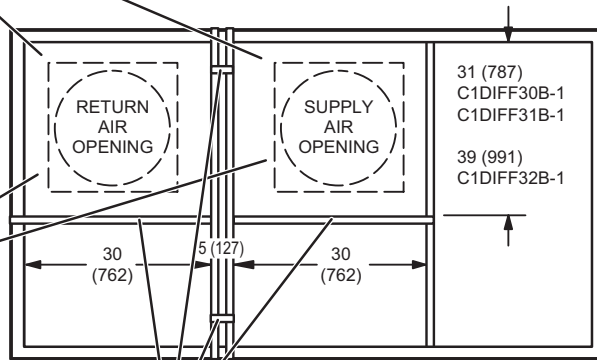
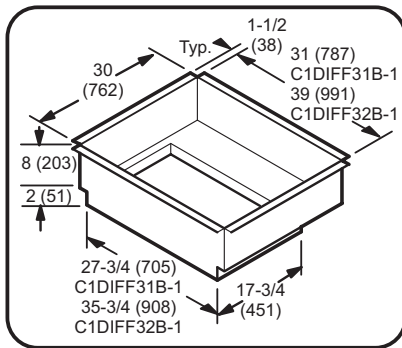

TOP VIEW

NOTE - These four supports are furnished with the transitions to replace supports furnished with curb for proper transition spacing.

**COMBINATION CEILING SUPPLY AND RETURN DIFFUSERS**

**STEP-DOWN CEILING DIFFUSER**

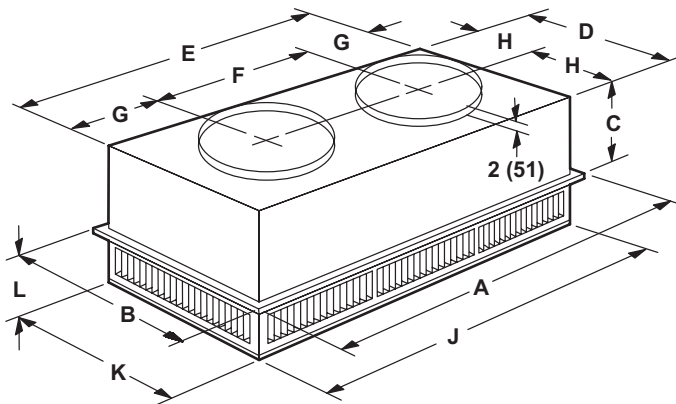

**FLUSH CEILING DIFFUSER**

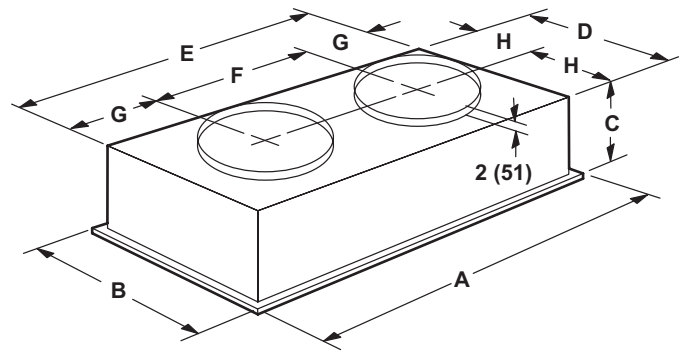

Model Number		RTD11-95S
A	in.	47-5/8
	mm	1159
B	in.	29-5/8
	mm	752
C	in.	14-3/8
	mm	365
D	in.	27-1/2
	mm	699
E	in.	45-1/2
	mm	1158
F	in.	22-1/2
	mm	572
G	in.	11-1/2
	mm	292
H	in.	13-3/4
	mm	349
J	in.	45-1/2
	mm	1156
K	in.	27-1/2
	mm	699
L	in.	8-1/8
	mm	206
Duct Size	in.	20 round
	mm	508 round

Model Number		FD11-95S
A	in.	47-5/8
	mm	1159
B	in.	29-5/8
	mm	752
C	in.	16-5/8
	mm	422
D	in.	27
	mm	686
E	in.	45
	mm	1143
F	in.	22-1/2
	mm	572
G	in.	11-1/4
	mm	286
H	in.	13-1/2
	mm	343
Duct Size	in.	20 round
	mm	508 round

**COMBINATION CEILING SUPPLY AND RETURN DIFFUSERS**

**STEP-DOWN CEILING DIFFUSER**

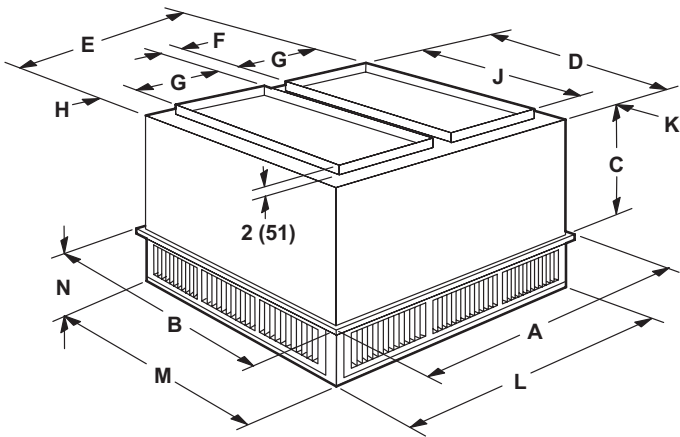

**FLUSH CEILING DIFFUSER**

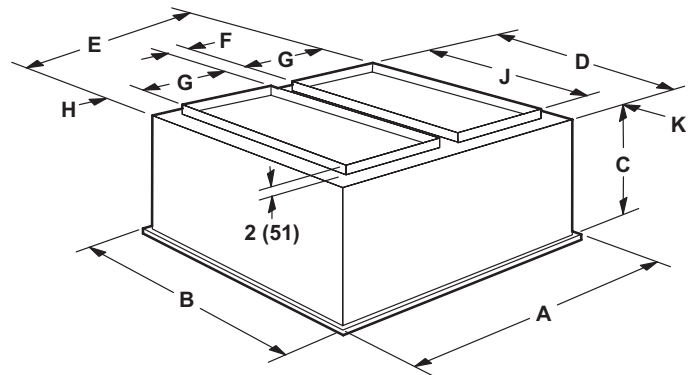

Model Number		RTD11-135S	RTD11-185S
A	in.	47-5/8	47-5/8
	mm	1210	1210
B	in.	35-5/8	47-5/8
	mm	905	1210
C	in.	20-5/8	24-5/8
	mm	524	625
D	in.	33-1/2	45-1/2
	mm	851	1156
E	in.	45-1/2	45-1/2
	mm	1156	1156
F	in.	4-1/2	4-1/2
	mm	114	114
G	in.	18	18
	mm	457	457
H	in.	2-1/2	2-1/2
	mm	64	64
J	in.	28	36
	mm	711	914
K	in.	2-3/4	4-3/4
	mm	70	121
L	in.	45-1/2	45-1/2
	mm	1156	1156
M	in.	33-1/2	45-1/2
	mm	851	1156
N	in.	9-1/8	10-1/8
	mm	232	257
Duct Size	in.	18 x 28	18 x 36
	mm	457 x 711	457 x 914

Model Number		FD11-135S	FD11-185S
A	in.	47-5/8	47-5/8
	mm	1210	1210
B	in.	35-5/8	47-5/8
	mm	905	1210
C	in.	23-1/4	29-1/4
	mm	591	743
D	in.	33	45
	mm	838	1143
E	in.	45	45
	mm	1143	1143
F	in.	4-1/2	4-1/2
	mm	114	114
G	in.	18	18
	mm	457	457
H	in.	2-1/4	2-1/4
	mm	57	57
J	in.	28	36
	mm	711	914
K	in.	2-1/2	4-1/2
	mm	64	114
Duct Size	in.	18 x 28	18 x 36
	mm	457 x 711	457 x 914



## REVISIONS

Section	Description
Options/Accessories	Combination Coil/Hail Guards - catalog number change.



Visit us at [www.Lennox.com](http://www.Lennox.com)

For the latest technical information, [www.LennoxCommercial.com](http://www.LennoxCommercial.com)

Contact us at 1-800-4-LENNOX

NOTE - Due to Lennox' ongoing commitment to quality, Specifications, Ratings and Dimensions subject to change without notice and without incurring liability. Improper installation, adjustment, alteration, service or maintenance can cause property damage or personal injury. Installation and service must be performed by a qualified installer and servicing agency.

©2023 Lennox Industries, Inc.